



HLAE - HYGIENIC DESIGN

PLANETARY GEARBOXES



The unique planetary gearbox in a certified hygienic design – ideal for safe and hygienic processes in the pharmaceutical, food and beverage industries.

Hygienic Design



Our HLAE gearbox is not just a stainless steel gearbox. The HLAE series is the consistent response to the hygiene requirements of the pharmaceutical and food processing industries.

Not only is the material used crucial; the geometry and design are as well.

The most basic requirement for machines and components in the pharmaceutical and food industries is that they leave no room for contamination. Pockets of dirt or biofilms containing germs and bacteria can form on edges, in corners and dead spaces. The hygienic design of the HLAE gearbox has no dead spaces. Corners and edges are generously rounded to prevent any accumulation. The electropolished stainless steel surface and the special seals also allow regular cleaning, even with aggressive or caustic cleaning agents.

Dirt doesn't have a chance on the HLAE! And this is unique: It is the world's first planetary gearbox in a certified hygienic design - flexible without a radial bolt, powerful and yet easy and quick to clean.

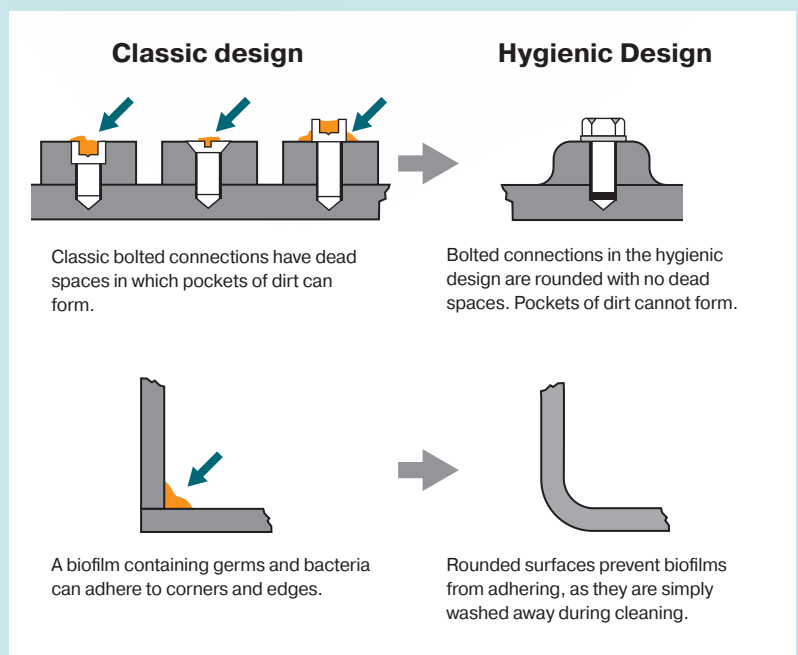

Food processing industry

Perfect functionality, residue-free cleaning of your food or beverage equipment - whether you are processing, dispensing, cutting, positioning or packaging.

The HLAE series keeps your processes running and can be quickly cleaned and disinfected after the work is done.

Typical applications:

- Filling systems and dispensing equipment
- Slicers
- Form and fill equipment
- Mechanical conveyors
- Mixers and agitators

... and all applications where the Cleaning-in-Place (CIP) process is used.



Pharmaceutical industry



The most demanding requirements regarding surface texture coupled with the most reliable technology – this is what you can expect from HLAE series gearboxes, which are made of hygienic steel.

The product can be used without hesitation for portioning, dispensing, pressing or centrifuging in the pharmaceutical and cosmetics sectors. This is because even the finest powder can hardly adhere to the electropolished surface with a mean roughness value R_a of $< 0.8 \mu\text{m}$.

Typical applications:

- Stirring machines / cone mixers
- Capsule filling systems
- Centrifuges

It's the details that count ...

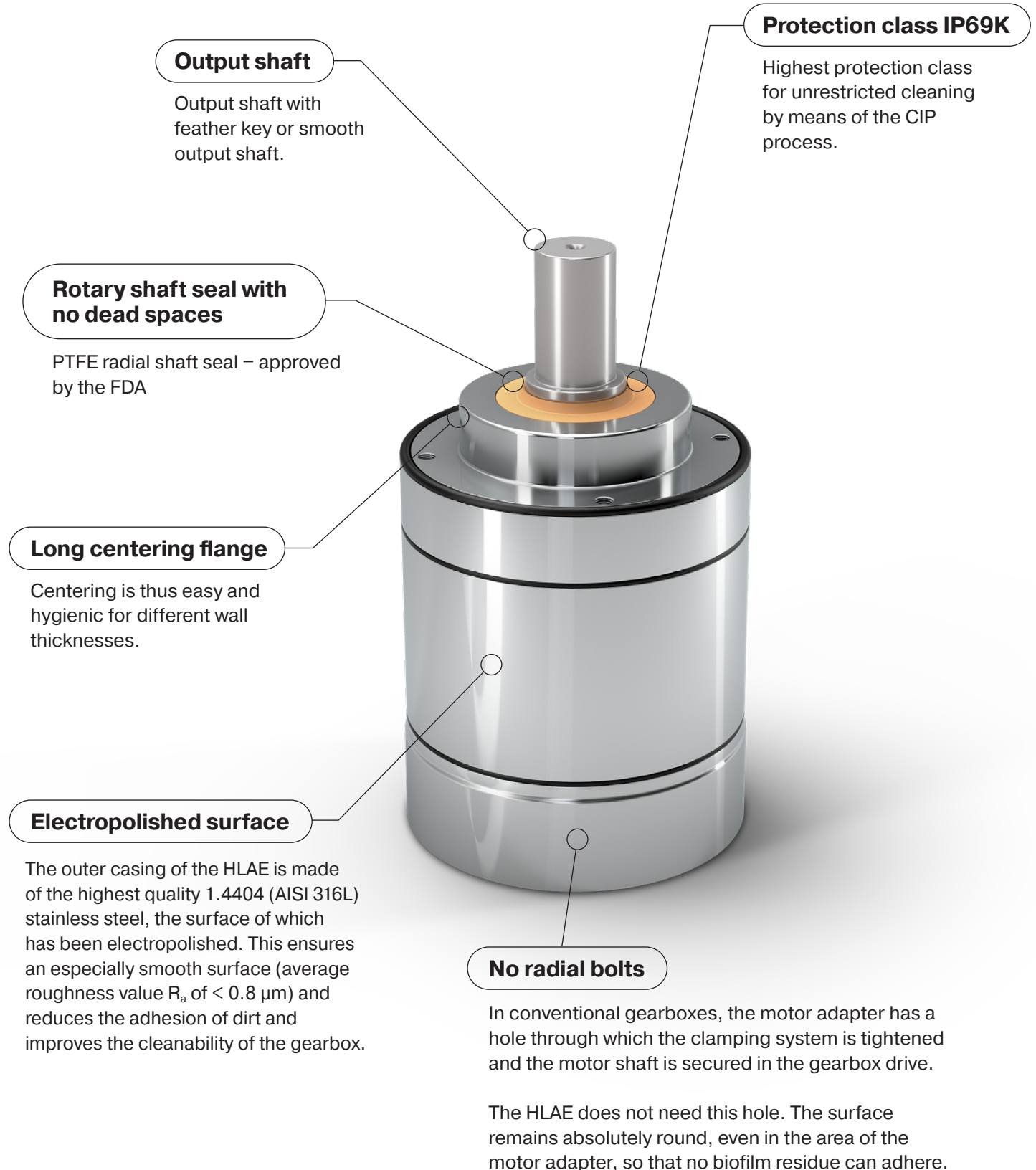

... also inside

Food grade lubrication

With H1 approval from the NSF. Halal and kosher.

Straight teeth & planetary carrier in disk version

The straight teeth impress with their high precision and up to 7 arcmin torsional backlash as well as high power density.

With this planetary carrier design, the mass inertia of the gearbox is reduced and the dynamics are therefore significantly increased.

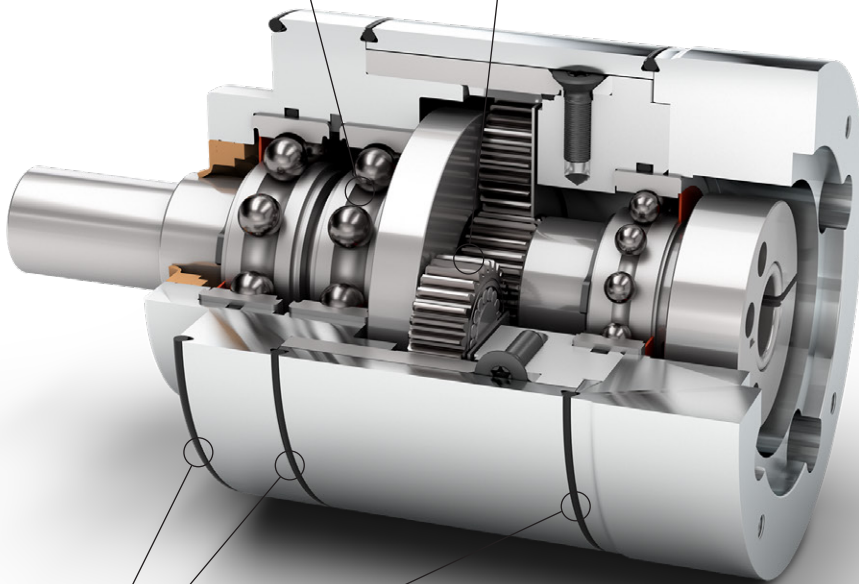

O-rings with FDA approval

EPDM (standard)

Temperature range -50°C to +140°C

The typical area of application is wherever high resistance of the seals exposed to hot water and steam is required. Moreover, EPDM has very good aging and ozone resistance. The chemical resistance, even to oxidizing agents, is very good.

FFKM (optional)

Temperature range -15°C to +325°C

FFKM seals increase the temperature range and have very good chemical resistance. FFKM is used in areas where other elastomer materials have reached their limits.

Two motor mounting options available:

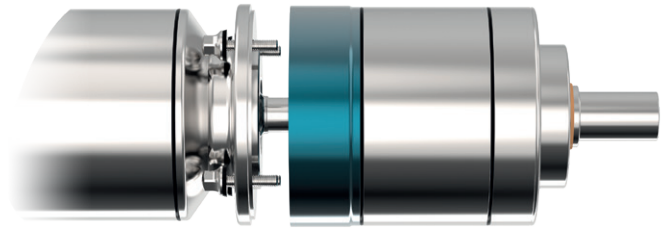

B5 motor flange

The motor is bolted directly to the gearbox via through holes in the motor flange. Large number of different motor adapters available for the gearbox, enabling hygienic and simple adaptation to different motors.

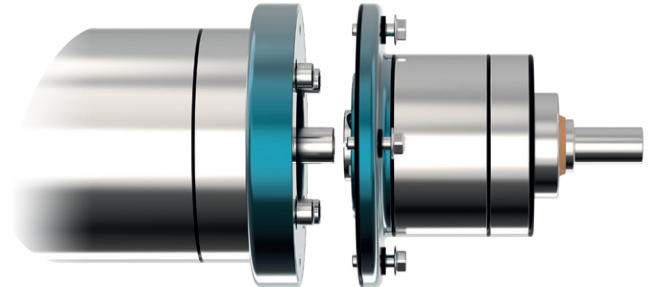

B14 motor flange

An additional adapter, which is bolted to the motor, establishes the hygienic connection to the gearbox.



Configure the appropriate motor-gearbox combination for your application with just a few clicks using our Tec Data Finder (TDF) at: www.neugart.com

Optional seal kit

To further ensure a comprehensive hygienic design on the application side, the HLAE seal kit is available as an option.

The freely positionable seal kit of the HLAE is universally applicable for use with different wall thicknesses and provides maximum hygienic protection.

The seals used in the seal kit further ensure that dead spaces are eliminated. Like the HLAE planetary gearbox, the materials are based on stainless steel and can be cleaned accordingly.

This gives you maximum flexibility when connecting to applications while complying with the highest hygienic requirements.

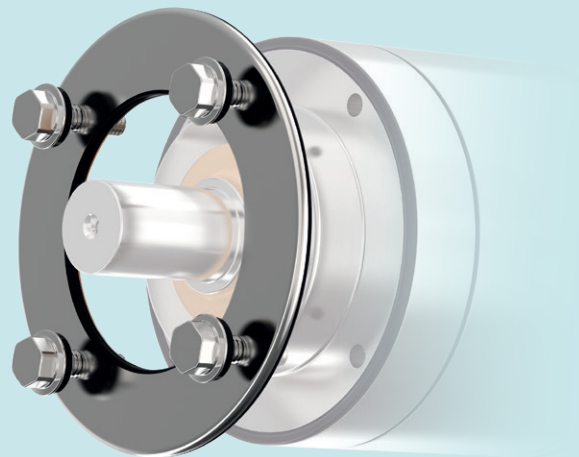

Seal kit (gearbox side)			
For gearbox series	HLAE070	HLAE090	HLAE110
Article number	63911	63858	64130

Certifications



3-A RPSCQC

The HLAE is the world's first planetary gearbox in a hygienic design certified to 3-A RPSCQC standards.



NSF H1 lubricant

The inside of the HLAE is also made with certified materials. The lubricant used is certified to NSF H1, guaranteeing that the product can be used in the food industry without any health risks. In addition, the lubricant also has halal and kosher approval.



FDA

The materials for the components used in the HLAE, e.g. radial shaft seal and O-rings, are FDA approved.



IP69K

Products in food processing machines are subject to the harshest environmental conditions. The HLAE is designed to provide the highest possible protection rating (IP69K), making it suitable for cleaning-in-place (CIP).

Technical data

Code	Gearbox characteristics			HLAE070	HLAE090	HLAE110	p ⁽¹⁾
	Service life (L _{10h})	t _L	h	30.000			
	Efficiency at full load ⁽²⁾	η	%	98			1
				97			2
	Min. operating temperature	T _{min}	°C (°F)	-25 (-13)			
	Max. operating temperature	T _{max}		90 (194)			
	Protection class		IP69K				
F	Food grade lubrication		Grease (lifetime lubrication)				
	Installation position		Any				
S	Standard backlash	j _t	arcmin	< 10	< 7	< 7	1
				< 12	< 9	< 9	2
	Torsional stiffness ⁽²⁾	c _g	Nm /arcmin (lb _f .in/arcmin)	2,3 - 3,1 (20 - 27)	6,6 - 8,7 (58 - 77)	14,7 - 19,5 (130 - 173)	1
				2,2 - 3,2 (19 - 28)	6,6 - 9,0 (58 - 80)	13,5 - 20,5 (119 - 181)	2
	Gearbox weight ⁽²⁾	m _G	kg (lb _m)	2,1 (4.6)	3,8 (8.4)	7,3 - 7,4 (16.1 - 16.4)	1
				2,4 - 2,5 (5.2 - 5.6)	4,3 - 4,5 (9.5 - 9.9)	8,7 - 9,0 (19.1 - 19.9)	2
S	Standard surface			Housing: Stainless steel 1.4404 (AISI 316L) – electropolished (R _a < 0,8 μm)			
	Running noise ⁽³⁾	Q _g	dB(A)	58	60	65	
	Max. bending moment based on the gearbox input flange ⁽⁴⁾	M _b	Nm (lb _f .in)	8 (71)	16 (142)	40 (354)	

Output shaft loads			HLAE070	HLAE090	HLAE110	p ⁽¹⁾
Radial force for 20,000 h ⁽⁵⁾⁽⁶⁾	F _{r 20.000 h}	N (lb _f)	450 (101)	900 (202)	1450 (326)	
Axial force for 20,000 h ⁽⁵⁾⁽⁶⁾	F _{a 20.000 h}		550 (124)	1500 (337)	2500 (562)	
Radial force for 30,000 h ⁽⁵⁾⁽⁶⁾	F _{r 30.000 h}		400 (90)	600 (135)	1250 (281)	
Axial force for 30,000 h ⁽⁵⁾⁽⁶⁾	F _{a 30.000 h}		500 (112)	1000 (225)	2000 (450)	
Maximum radial force ⁽⁶⁾⁽⁷⁾	F _{r Stat}		1000 (225)	1250 (281)	5000 (1124)	
Maximum axial force ⁽⁶⁾⁽⁷⁾	F _{a Stat}		1200 (270)	1600 (360)	3800 (854)	
Tilting moment for 20,000 h ⁽⁵⁾⁽⁷⁾	M _{K 20.000 h}	Nm (lb _f .in)	22 (195)	49 (434)	109 (965)	
Tilting moment for 30,000 h ⁽⁵⁾⁽⁷⁾	M _{K 30.000 h}		19 (168)	33 (292)	94 (832)	

Moment of inertia			HLAE070	HLAE090	HLAE110	p ⁽¹⁾
Mass moment of inertia ⁽²⁾	J	kgcm ² (lb _f .in.s ² 10 ⁻⁴)	0,065 - 0,135 (0.575 - 1.195)	0,753 - 0,866 (6.665 - 7.665)	1,579 - 2,630 (13.975 - 23.277)	1
			0,064 - 0,131 (0.566 - 1.159)	0,740 - 0,983 (6.550 - 8.700)	1,569 - 2,620 (13.887 - 23.189)	2

⁽¹⁾ Number of stages

⁽²⁾ The ratio-dependent values can be retrieved in Tec Data Finder – www.neugart.com

⁽³⁾ Sound pressure level from 1 m, measured on input running at n₁=3000 rpm no load; i=5

⁽⁴⁾ Max. motor weight* in kg = 0.2 x M_b / motor length in m

* with symmetrically distributed motor weight

* with horizontal and stationary mounting

⁽⁵⁾ These values are based on an output shaft speed of n₂=100 rpm

⁽⁶⁾ Based on center of output shaft

⁽⁷⁾ Other (sometimes higher) values following changes to T_{2N}, F_r, F_a, cycle, and service life of bearing.

Application specific configuration with NCP – www.neugart.com

Technical data

Output torques			HLAE070	HLAE090	HLAE110	i ⁽¹⁾	p ⁽²⁾				
Nominal output torque ⁽³⁾⁽⁴⁾	T _{2N}	Nm (lb _f .in)	28 (248)	85 (752)	115 (1018)	3	1				
			33 (292)	87 (770)	155 (1372)	4					
			30 (266)	82 (726)	171 (1513)	5					
			25 (221)	65 (575)	135 (1195)	7					
			18 (159)	50 (443)	120 (1062)	8					
			15 (133)	38 (336)	95 (841)	10					
			33 (292)	87 (770)	157 (1390)	9	2				
			33 (292)	80 (708)	171 (1513)	12					
			33 (292)	82 (726)	171 (1513)	15					
			33 (292)	87 (770)	171 (1513)	16					
			33 (292)	87 (770)	171 (1513)	20					
			30 (266)	82 (726)	171 (1513)	25					
			33 (292)	87 (770)	171 (1513)	32					
			30 (266)	82 (726)	171 (1513)	40					
			18 (159)	50 (443)	120 (1062)	64					
			15 (133)	38 (336)	95 (841)	100					
			Max. output torque ⁽⁴⁾⁽⁵⁾	T _{2max}	Nm (lb _f .in)	45 (398)		136 (1204)	184 (1629)	3	1
						53 (469)		140 (1239)	248 (2195)	4	
48 (425)	131 (1159)	274 (2425)				5					
40 (354)	104 (920)	216 (1912)				7					
29 (257)	80 (708)	192 (1699)				8					
24 (212)	61 (540)	152 (1345)				10					
53 (469)	140 (1239)	251 (2222)				9	2				
53 (469)	140 (1239)	274 (2425)				12					
53 (469)	131 (1159)	274 (2425)				15					
53 (469)	140 (1239)	274 (2425)				16					
53 (469)	140 (1239)	274 (2425)				20					
48 (425)	131 (1159)	274 (2425)				25					
53 (469)	140 (1239)	274 (2425)				32					
48 (425)	131 (1159)	274 (2425)				40					
29 (257)	80 (708)	192 (1699)				64					
24 (212)	61 (540)	152 (1345)				100					

⁽¹⁾ Ratios (i=n₁/n₂)

⁽²⁾ Number of stages

⁽³⁾ Application specific configuration with NCP – www.neugart.com

⁽⁴⁾ Values for feather key (code "A"): for repeated load

Technical data

Output torques			HLAE070	HLAE090	HLAE110	i ⁽¹⁾	p ⁽²⁾
Emergency stop torque ⁽³⁾	T _{2Stop}	Nm (lb _f .in)	56 (496)	170 (1505)	230 (2036)	3	1
			66 (594)	174 (1540)	310 (2744)	4	
			60 (531)	164 (1452)	342 (3027)	5	
			50 (443)	130 (1151)	270 (2390)	7	
			36 (319)	100 (885)	240 (2124)	8	
			30 (266)	76 (673)	190 (1682)	10	
			66 (584)	174 (1540)	314 (2779)	9	2
			66 (584)	174 (1540)	342 (3027)	12	
			66 (584)	164 (1452)	342 (3027)	15	
			66 (584)	174 (1540)	342 (3027)	16	
			66 (584)	174 (1540)	342 (3027)	20	
			60 (531)	164 (1452)	342 (3027)	25	
			66 (584)	174 (1540)	342 (3027)	32	
			60 (531)	164 (1452)	342 (3027)	40	
			36 (319)	100 (885)	240 (2124)	64	
			30 (266)	76 (673)	190 (1682)	100	

Input speeds			HLAE070	HLAE090	HLAE110	i ⁽¹⁾	p ⁽²⁾				
Average thermal input speed at T _{2N} and S1 ⁽⁴⁾	n _{1N}	min ⁻¹	4000 ⁽⁵⁾	2700 ⁽⁵⁾	2000 ⁽⁵⁾	3	1				
			4000 ⁽⁵⁾	3000 ⁽⁵⁾	2000 ⁽⁵⁾	4					
			4000	3400 ⁽⁵⁾	2150 ⁽⁵⁾	5					
			4000	3500 ⁽⁵⁾	2600 ⁽⁵⁾	7					
			4000	3500	2800 ⁽⁵⁾	8					
			4000	3500	3000 ⁽⁵⁾	10					
			4000	3500 ⁽⁵⁾	2400 ⁽⁵⁾	9	2				
			4000	3500 ⁽⁵⁾	2450 ⁽⁵⁾	12					
			4000	3500	2550 ⁽⁵⁾	15					
			4000	3500	2650 ⁽⁵⁾	16					
			4000	3500	2850 ⁽⁵⁾	20					
			4000	3500	2950 ⁽⁵⁾	25					
			4000	3500	3000 ⁽⁵⁾	32					
			4000	3500	3000	40					
			4000	3500	3000	64					
			4000	3500	3000	100					
			Max. mechanical input speed ⁽⁴⁾	n _{1Limit}	min ⁻¹	13000		7000	6500		

⁽¹⁾ Ratios (i=n₁/n₂)

⁽²⁾ Number of stages

⁽³⁾ Permitted 1000 times

⁽⁴⁾ Application-specific speed configurations with NCP – www.neugart.com

⁽⁵⁾ Average thermal input speed at 50% T_{2N} and S1

Dimensions

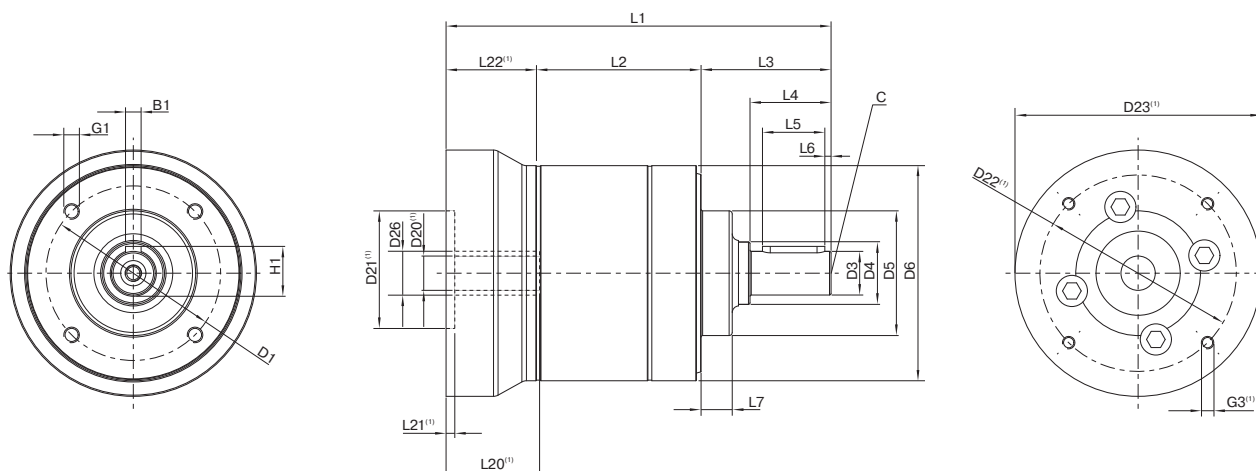

Drawing corresponds to a HLAE070 / 1-stage / output shaft with feather key / 11 mm clamping system / motor adaptation – one part / B5 flange type motor

⁽¹⁾ The dimensions vary with the motor/gearbox flange. The input flange dimensions can be retrieved for each specific motor in Tec Data Finder at www.neugart.com

Geometry ⁽²⁾			HLAE070	HLAE090	HLAE110	p ⁽³⁾	Code
Pitch circle diameter output	D1		56 (2.205)	75 (2.953)	90 (3.543)		
Shaft diameter output	D3	h7	14 (0.551)	20 (0.787)	25 (0.984)		
Shaft collar output	D4		20 (0.787)	25 (0.984)	35 (1.378)		
Centering diameter output	D5	h7	40 (1.575)	58 (2.283)	65 (2.559)		
Housing diameter	D6		69 (2.717)	88 (3.465)	109 (4.291)		
Mounting thread x depth	G1	4x	M5x11	M6x12	M8x20		
Min. total length	L1		123,5 (4.862)	146 (5.748)	191 (7.520)	1	
			135,5 (5.335)	166 (6.535)	219 (8.622)	2	
Housing length	L2		52,8 (2.079)	68,0 (2.677)	89,0 (3.504)	1	
			64,8 (2.551)	88,0 (3.465)	117,0 (4.606)	2	
Shaft length output	L3		41,7 (1.642)	50 (1.969)	66,5 (2.168)		
Centering depth output	L7		10 (0.394)	13 (0.512)	14 (0.551)		
Motor shaft diameter j6/k6	D20		The input flange dimensions can be retrieved for each specific motor in Tec Data Finder at www.neugart.com				
Clamping system diameter input	D26		11/14	19	24		
Output shaft with feather key (DIN 6885-1)			A 5x5x20	A 6x6x25	A 8x7x35		
Feather key width (DIN 6885-1)	B1		5 (0.197)	6 (0.236)	8 (0.315)		A
Shaft height including feather key (DIN 6885-1)	H1		16 (0.630)	22,5 (0.886)	28 (1.102)		
Shaft length from shoulder	L4		26 (1.024)	32 (1.260)	45 (1.772)		
Feather key length	L5		20 (0.787)	25 (0.984)	35 (1.378)		
Distance from shaft end	L6		2 (0.079)	2,5 (0.098)	5 (0.197)		
Center hole (DIN 332, type DR)	C		M5x12,5	M6x16	M10x22		
Smooth output shaft							
Shaft length from shoulder	L4		26 (1.024)	32 (1.260)	45 (1.772)		B

⁽²⁾ Dimensions in mm

⁽³⁾ Number of stages



Do you have any questions or require any more information?

We will gladly advise you on all topics relating to drive technology.

You can find your personal contact at: www.neugart.com

Neugart GmbH

Keltenstraße 16
77971 Kippenheim
Deutschland
Phone: +49 7825 847-0
Fax: +49 7825 847-2999
Email: sales@neugart.com
Web: www.neugart.com

Neugart USA Corp.

14325 South Lakes Drive
Charlotte, NC 28273
USA
Phone: +1 980 299-9800
Fax: +1 980 299-9799
Email: sales@neugartusa.com
Web: www.neugart.com/en-us

Neugart Planetary Gearboxes (Shenyang) Co., Ltd.

No. 152, 22nd road
E&T Development Zone Shenyang, PC 110143
PR China
Phone: +86 24 2537-4959
Fax: +86 24 2537-2552
Email: sales@neugart.net.cn
Web: www.neugart.net.cn