



Conveyor Components

Issue 16

CONVEYOR COMPONENTS

- Chain Guide Components Page S002
- Product Handling Components Page S045
- Frame Support Components Page S140
- Miscellaneous Components Page S156

S001 - S189



SUPPORTING AND LEVELLING ELEMENTS

- Articulated Feet in Reinforced Polyamide Page R08
- Articulated Feet Gripper Page R21
- Articulated Feet in Steel Page R34
- Fixed Feet in Steel Page R41
- Threaded Bushings Page R42

R00 - R43



SELF-ALIGNING BEARINGS

- Square Flange Bearing Units Page B04
- Oval Flange Bearing Units Page B14
- Pillow Block Type Bearing Units Page B22
- Compact Pillow Block Type Bearing Units Page B26
- Side Flange Bearing Units Page B28
- Take-up Bearing Units Page B36
- Round Flange Bearing Units Page B38

B00 - B59





The company

Rexnord is a global company supplying many industries with power transmission and conveying components. The product offering ranges from roller chains, couplings and geared products to conveyor chains, belts and components.

The head office is based in the United States, with several divisions all over the world. The Rexnord FlatTop division is manufacturing conveyor chains, belts and components.

Rexnord is fully committed to meet customer expectations; huge knowledge of the business reduces maintenance costs, eliminates redundant inventories and prevents downtime, all in close co-operation with OEMs and end users. This is a result of Rexnord's focus on product development, application engineering, operations and customer service.

Rexnord FlatTop Europe represents 3 strong brands: Rexnord, MCC and Marbett.

With production facilities in 's-Gravenzande and Correggio, sales offices in The Netherlands and Italy, a large sales group for local service in many countries and distributors all over the world, Rexnord is always close to its customers. In this way a fast and reliable delivery is guaranteed.

Rexnord chains and belts are being used to convey a wide variety of products: bottles, cans, boxes, crates, tires, loose food, glass jars, PET containers, trays; shortly every transport in production halls in virtually any industry.

The product range has been split up over two catalogues, one for Rexnord/MCC Table Top/MatTop chains and one for Marbett conveyor components.

The industries served

As the handling specialist in the field of conveying, the Rexnord product portfolio is providing solutions for complete lines in several industries in order to improve productivity.

In beverage industry palletizers, depalletizers, washers, labelers, fillers, pasteurizers, inliners, outfeeds, elevators and accumulation tables are equipped with slatband chains, curves, sprockets, belts, bearings, leveling elements and many more conveyor components.



For the container manufacturing industry special products and materials are available, such as abrasion resistant polyamide for glass plants, vacuum chains for can making and gripper chains for vertical transport.



A wide range of products is also offered for blanchers, cookers, washers, coolers and processing lines in fruit, vegetables, bakery, confectionary etc. And many more products are available for the handling of packed food.



In automotive industry the products are engineered to meet the most demanding applications, such as rubber processing and tire handling.

This is just a short selection of the applications in which Rexnord products are being used. Among others they have also found their way into pharmaceutical production lines, battery manufacture, paper and cardboard production.

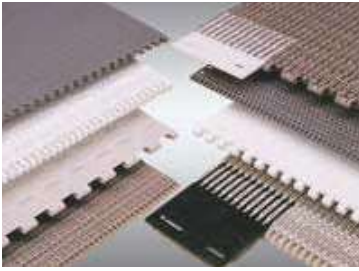

Rexnord and MCC TableTop chains and MatTop belts

The product line can be split up into:



- **Steel slatband chains**
In various materials ranging from carbon steel to special stainless steel with better wear and sliding properties; types straight running, sideflexing tab, bevel and Magnetflex, with and without rubber top.

- **Plastic slatband chains**

Wide range of materials and various executions; single hinge, double hinge, heavy duty, vacuum, lbp rollers and rubber top.



- **Plate Top and Gripper chains**
Based on the Rexnord roller chains in both stainless and carbon steel; Plate Top chains have steel or plastic top plates; Gripper chains have different types of rubber inserts.

- **Case conveyor and Multiflex chains**
Different types of acetal for both straight running and sideflexing transport of products varying from heavy crates to small juice packs.



- **Curves**
Magnetflex, Tab and bevel, as well as straight tracks to support the chain in all parts of the line; there are many standard versions besides the ability to make any special curve needed

in your applications with short delivery times.

- **Modular belts**

Pitches differ from 0.5 to 2.25 inch to suit any application. Most series have both closed and open top executions; some also available with rubber top for inclined conveying.

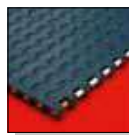

Marbett conveyor components

The product line can be split up into:

- **Chain guide components**

Profiles, corner tracks, straight tracks, return rollers, serpentine, plugs for connections.



- **Product handling components**
Guide rails, roller guides, guide rail clamps, guide rail brackets and connecting clamps in plastic or stainless steel.

- **Frame support components**

Side mounting top brackets, bearing heads, support bases and connecting joints, stainless steel components.



- **Supporting and leveling elements**
Different versions in steel and plastic, articulated and fixed, with and without gripper bottom and vibration absorbing feet.

- **Self-aligning bearings**

Square, oval, pillow block, side flange, take-up, round, and other executions, all with open and closed unit. Lubricated for life versions are also available.



- **Miscellaneous components** Line control elements, hinges, locks, knobs, modular transfer roller plates, rollers, tensioners, nozzles, cable carriage chains, shaft collars and nose-over bars.

CHAIN GUIDE COMPONENTS

Chain Guide Profiles Page S002

Roller Guides for Chain Return Page S027

Serpentine Guides for Chain Return Page S036

Plugs for Connection Page S042



PRODUCT HANDLING COMPONENTS

Product-Guides Page S043

Guide-Rail Clamps Page S086

Guide-Rail Brackets Page S102

Connecting Clamps Page S118



FRAME SUPPORT COMPONENTS

- Side Mounting top Brackets Page S122
- Bearing Heads Page S124
- Support Bases Page S126
- Connecting Joints Page S180
- Support Heads (Stainless steel) Page S130
- Connecting Joints (Stainless steel) Page S134



MISCELLANEOUS COMPONENTS

- Line Control Elements Page S136
- Hinges Page S140
- Locks Page S142
- Tightening Elements Page S143
- Modular transfer roller plate Page S146
- Modular Nose-Over Bar Page S150
- Shaft collars Page S152
- Winding Tensioners Page S154
- Side Guide Adjustment Page S156



TECHNICAL INFORMATION

Technical information Page S162

SQUARE FLANGE BEARING**Pag. B04 - B13****OVAL FLANGE BEARING****Pag. B14 - B21****PILLOW BLOCK BEARING****Pag. B22 - B25****COMPACT PILLOW
BLOCK BEARING****Pag. B26 - B27**

SIDE FLANGE BEARING

Pag. B28 - B35



TAKE-UP BEARING

Pag. B36 - B37



ROUND FLANGE BEARING

Pag. B38 - B43



TECHNICAL INFORMATIONS

Technical Informations see Pag. B45 - B59

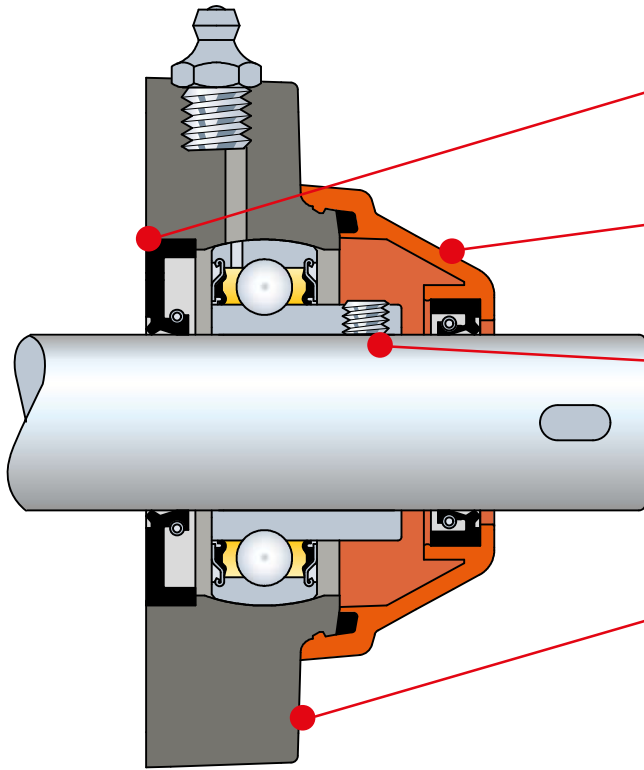

Waterproof housing

The waterproof sealing system guarantees protection of the bearing from the external environment

Inspectable bearing

The clip-on protection cover can be removed for bearing inspection

Locking by grub screws

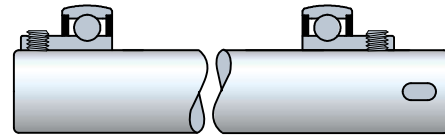

ISO dimensions

The overall dimensions can be interchanged with the corresponding cast iron type bearings

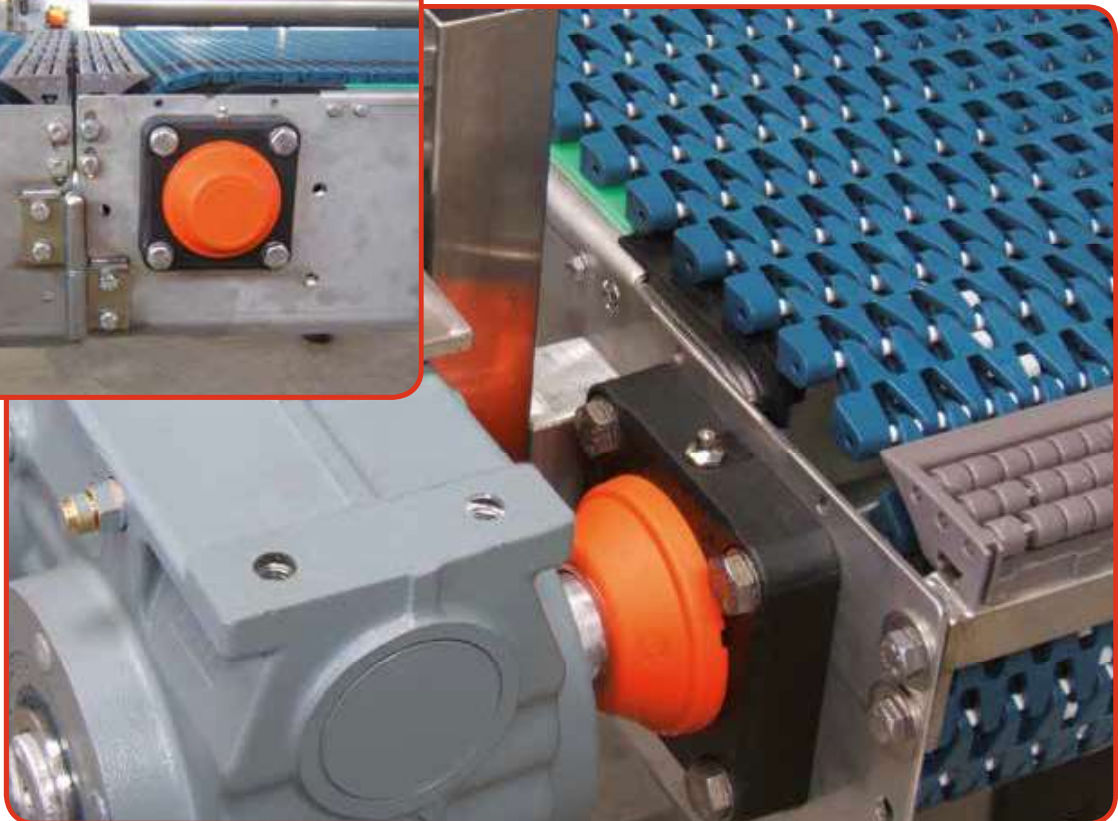

- Overall dimensions of self-aligning bearings are in accordance with ISO 3228 standards
- All self-aligning bearings are interchangeable with their correspondent cast iron versions



ISO dimensions

- Self-aligning bearings are equipped with stainless steel AISI 304/316 bushes to reinforce mounting holes
- The reinforcing bushings avoid damages to the plastic flange during screw tightening



Fixing bushes

- Only best quality glass fibre reinforced polyamide PA FV/polypropylene PP FV thermoplastic resins are used for the self-aligning housings
- The resins used guarantee high resistance to oxidation and corrosion and at the same time equal the strength offered by cast iron housings. They offer a better resistance to impact
- Polyamide PA FV resins offer maximum heat and mechanical resistance
- Polypropylene PP FV resins offer maximum resistance to chemical agents



Thermoplastic resins

- A system of waterproof seals protects the bearing from external environment
- Protection from dust, humidity, washouts, chemical agents
- The clip-on protection cover allows inspection of the bearing

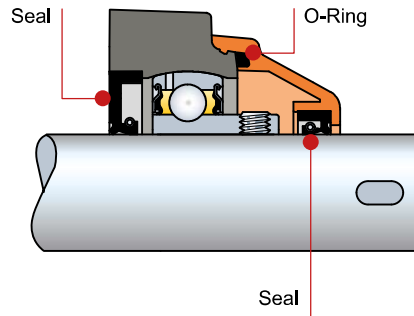

Waterproof housing

- Self-aligning bearings are equipped with ball bearings featuring multipurpose sealing systems.
- **A - D** - Superagriseal unit. The system consists of a metallic ring fitted with a low friction rubber sealing lip
- **B** - Superagriseal unit + centrifuging ring. The system is further equipped with a metallic protection ring providing a centrifugal sealing action.
- **C steel** - Superagriseal unit + rubberised centrifuging ring. This system is used in stainless steel bearings. The upper lip of the centrifuging ring together with the grease trapped between the base seal and the ring itself guarantees maximum sealing capacity.

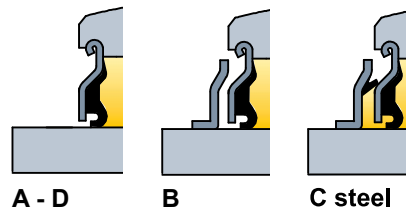

Bearing seals

- Waterproof self-aligning bearings feature seals for the protection against external environment
- Viton rubber seals ensure maximum resistance to chemical agents

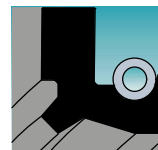

Support seals

- All bearings are self-aligning, capable of compensating misalignments up to 2°

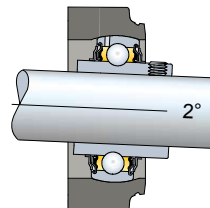

Misalignment

Square flange bearing units

UCF/C - SUCF/C - HCF/C - SHCF/C



Waterproof housing

Grub screws or eccentric collar shaft locking

PA FV polyamide housing

High mechanical and heat resistance. Proof to dust, humidity, washouts, steam, average aggressive chemical agents.

PP FV polypropylene housing

Proof to highly aggressive chemical agents. Inferior loading ability.

Solid flange bearings

They differ from standard flange versions for their closed surface structure, ideal for sanitation.

Material

PA FV polyamide housing

- Housing in reinforced polyamide PA FV resin (black)
- Protection cover in polypropylene PP (orange)
- Seal and O-Ring in NBR rubber (black)
- Ball type nickel plated brass greasing nipple
- Reinforcing bushings on mounting holes and washers in stainless steel AISI 304

Continuous operating temperature

in air: - 20 to + 60°C.

Maximum allowed misalignment: 2°.

Bearing



- Type A (grub screws shaft locking)
- Type D (eccentric collar shaft locking)
- Chrome alloy steel
- Superagriseal unit
- Prelubricated with lithium / calcium grease
- Can be relubricated.

• Series UCF/C • Type A Grub screws shaft locking

• Series HCF/C • Type D Eccentric collar shaft locking

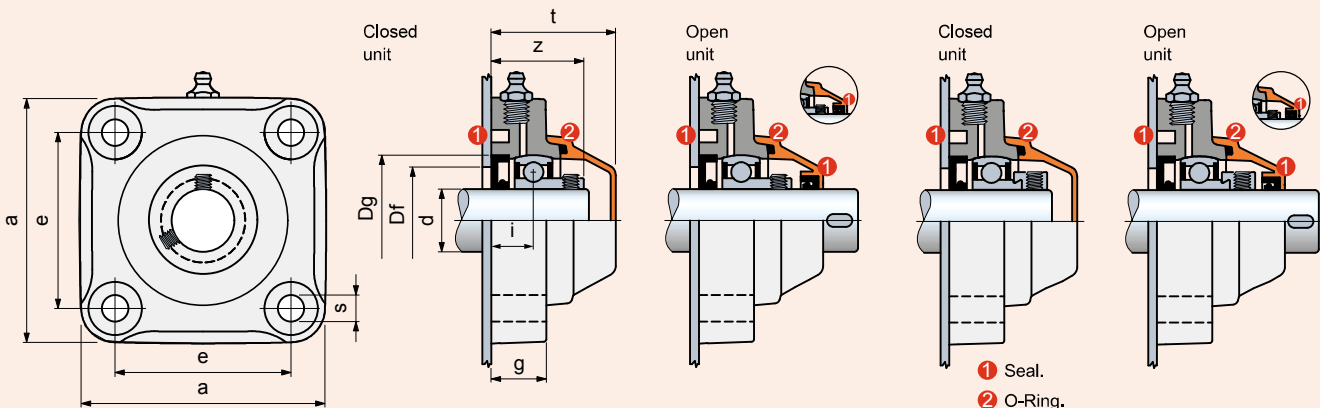

UCF/C - SUCF/C - HCF/C - SHCF/C

dia. d mm	Series	Housing material		Dimensions in mm								Bore in frame ²⁾ Df		Bearing	Weight Kg	Spare parts Cover orange	
		Polyamide PA FV Standard Flange (black) Cover (orange)	Code	e	a	s	g	i	z	t	Dg	max.	min.			Code	Code
Grub screws shaft locking • Closed unit																	
25	UCF 205 C	64573		70	98	11	22,5	16,8	36,3	49,5	52	50	45	Type A	0,40	681952	
30	UCF 206 C	63112		83	110	11	26	20	42	56	62	60	50	Type A	0,56	63154	
35	UCF 207 C	64018		92	120	11	26	19,5	43	59	72	70	55	Type A	0,72	682022	
35*	SUCF 207 C	680522 ¹⁾		83	110	11	26	19,5	43	61	72	70	55	Type A	0,67	63539	
40	UCF 208 C	68916		102	131	11	30	22	47	65,5	80	78	65	Type A	0,95	63539	
40*	SUCF 208 C	61819		83	110	11	26	19	44	66	80	78	65	Type A	0,88	600882	
Grub screws shaft locking • Open unit																	
25	UCF 205 C	64623		70	98	11	22,5	16,8	36,3	49,5	52	50	45	Type A	0,40	681972	
30	UCF 206 C	63172		83	110	11	26	20	42	56	62	60	50	Type A	0,56	69965	
35	UCF 207 C	64028		92	120	11	26	19,5	43	59	72	70	55	Type A	0,72	682032	
35*	SUCF 207 C	680582 ¹⁾		83	110	11	26	19,5	43	61	72	70	55	Type A	0,67	615692	
40	UCF 208 C	68926		102	131	11	30	22	47	65,5	80	78	65	Type A	0,95	63549	
40*	SUCF 208 C	61829		83	110	11	26	19	44	66	80	78	65	Type A	0,88	600892	
Eccentric collar shaft locking • Closed unit																	
40*	SHCF 208 C	62439		83	110	11	26	19	51,7	66	80	78	65	Type D	1,07	600882	
Eccentric collar shaft locking • Open unit																	
40*	SHCF 208 C	62449		83	110	11	26	19	51,7	66	80	78	65	Type D	1,07	600892	

* = Version with special fixing holes.

¹⁾ = Solid flange.

²⁾ = Dimensions Df max / Df min must be respected to ensure positive retention of the seals and to allow air bleeding during lubrication.

Packaging: 4 pieces.

Square flange bearing units

UCF/CL - SUCF/CL - HCF/CL - SHCF/CL

LIFE LUBRICATED



Dry use recommended



Life lubricated

The ball-bearings are pre-lubricated with a special grease keeping the bearing for its whole life. No need for re-lubrication (see page B56 to calculate the grease life)

Grub screws or eccentric collar shaft locking

PA FV polyamide housing

High mechanical and heat resistance. Proof to dust, average aggressive chemical agents.

Solid flange bearings

They differ from standard flange versions for their closed surface structure, ideal for sanitation.

Material

PA FV polyamide housing

- Housing in reinforced polyamide PA FV resin (black)
- Protection cover in polypropylene PP (orange)
- Seal and O-Ring in NBR rubber (black)
- Reinforcing bushings on mounting holes and washers in stainless steel AISI 304.

Continuous operating temperature

in air: - 20 to + 60°C.

Maximum allowed misalignment: 2°.

Bearing



- Type A (grub screws shaft locking)
- Chrome alloy steel
- Superagriseal unit
- Prelubricated with lithium / calcium grease, no need for re-lubrication.

• Series UCF/CL • Type A Grub screws shaft locking

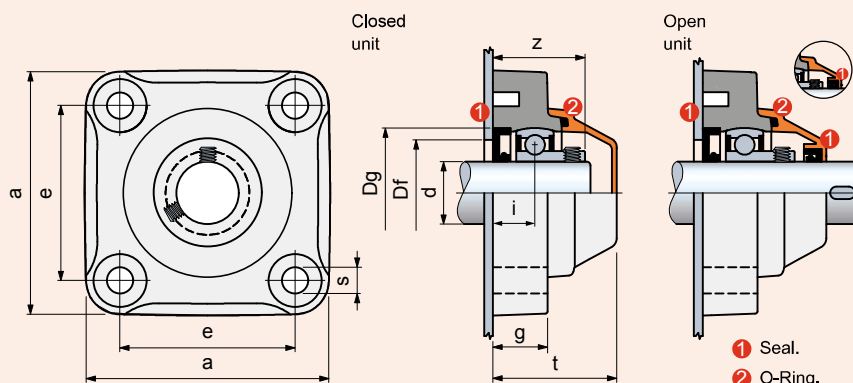

UCF/CL - SUCF/CL - HCF/CL - SHCF/CL

dia. d mm	Series	Housing material		Dimensions in mm										Bore in frame Df		Bearing	Weight Kg	Spare parts Cover orange	
		Polyamide PA FV Standard Flange (black) Cover (orange)	Code	e	a	s	g	i	z	t	Dg	max.	min.	Code	Code				
Grub screws shaft locking • Closed unit																			
40*	SUCF 208 CL	61819L	83	110	11	26	19	44	66	80	78	65	Type A	0,88	600882				
Grub screws shaft locking • Open unit																			
40*	SUCF 208 CL	61829L	83	110	11	26	19	44	66	80	78	65	Type A	0,88	600892				
Eccentric collar shaft locking • Closed unit																			
40*	SHCF 208 CL	62439L	83	110	11	26	19	51,7	66	80	78	65	Type D	1,07	600882				
Eccentric collar shaft locking • Open unit																			
40*	SHCF 208 CL	62449L	83	110	11	26	19	51,7	66	80	78	65	Type D	1,07	600892				

* = Version with special fixing holes.

Packaging: 4 pieces.

Square flange bearing units

UCF - SUCF - HCF - SHCF



Accessories

Material

PA FV polyamide housing

- Housing in reinforced polyamide PA FV resin (black)
- Ball type nickel plated brass greasing nipple
- Reinforcing bushings on mounting holes and washers in stainless steel AISI 304.

Continuous operating temperature

in air: - 20 to + 60°C.

Maximum allowed misalignment: 2°.

Bearing

- Type B (grub screws shaft locking, chrome alloy steel, Superagriseal unit plus centrifuging ring)
- Type C (grub screws shaft locking, stainless steel AISI 420, Superagriseal unit plus rubberised centrifuging ring)
- Type A (grub screws shaft locking, chrome alloy steel, Superagriseal unit)
- Type D (eccentric collar shaft locking, chrome alloy steel, Superagriseal unit)
- Prelubricated with lithium / calcium grease
- Can be relubricated.

Grub screws or eccentric collar shaft locking

Version with bearing Type B

The double ring guarantees maximum protection against dust and non-corrosive substances.

Version with stainless steel bearing Type C

AISI 420 stainless steel bearing with 2 rubberised rings, provides excellent seal against humidity, steams, liquids, medium corrosive chemical agents. Maximum load ability is inferior.

Version with bearing Type A

The rubberised ring guarantees maximum protection against dusts.

Material

Polyamide PA FV guarantees maximum strength and high-temperature resistance.

Protection covers (accessories)

Closed cover

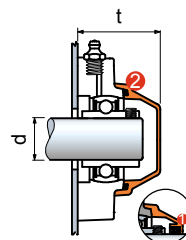

Dia 45/50 supplied without o-ring

Open cover

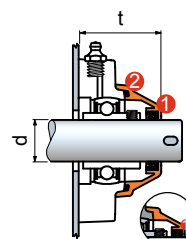

Dia 45/50 supplied without o-ring

1 Seals.

2 Seals O-Ring.

dia. d mm	Accessories	
	Cover orange Code	t mm
Closed cover supplied with seals		
25	681952	49,5
25*	681952	54
30	63154	56
35	682022	59
35* Standard	63154	54,6
40*	600882	66
Open cover supplied with seals		
25	681972	49,5
25*	681972	54
30	69965	56
35	682032	59
35* Solid	615692	61
40	63549	65,5

* = Version with special fixing holes.

• Series UCF • Type B
Grub screws shaft locking

• Series UCF • Type C
Grub screws shaft locking

• Series UCF • Type A
Grub screws shaft locking

• Series HCF • Type D
Eccentric collar shaft locking

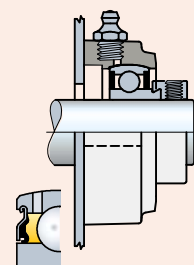
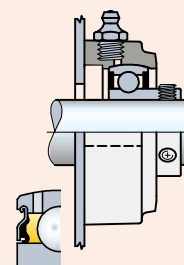
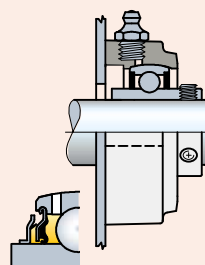
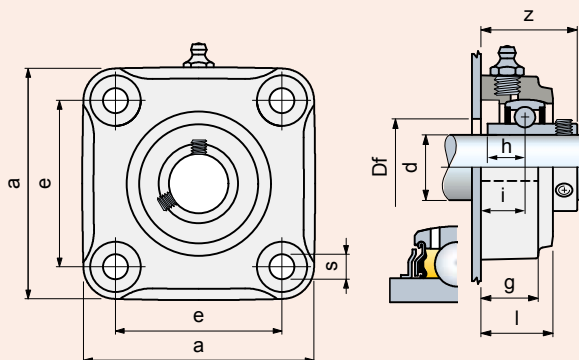

dia. d mm	Series	Housing material		Dimensions in mm								Bore in frame Df mm	Bearing	Weight Kg
		Polyamide PA FV Standard Flange (black)	Code	e	a	s	g	i	h	l	z			
Grub screws shaft locking • Version with bearing Type B														
25	UCF 205	64533		70	98	11	22,5	16,8	14,3	27,5	36,5	29	Type B	0,44
30	UCF 206	60722		83	110	11	26	20	15,9	32,5	42,2	34	Type B	0,57
35	UCF 207	64058		92	120	11	26	19,5	17,5	32	44,9	39	Type B	0,72
Grub screws shaft locking • Version with stainless steel bearing Type C														
25	UCF 205	646592		70	98	11	22,5	16,8	14,3	27,5	36,6	29	Type C	0,44
30	UCF 206	646602		83	110	11	26	20	15,9	32,5	42,2	34	Type C	0,57
Grub screws shaft locking • Version with bearing Type A														
25	UCF 205	656752		70	98	11	22,5	16,8	-	27,5	36,3	29	Type A	0,39
30	UCF 206	666442		83	110	11	26	20	-	32,5	42	34	Type A	0,54
35	UCF 207	666452		92	120	11	26	19,5	-	32	43	39	Type A	0,69
40	UCF 208	666462		102	131	11	30	22	-	36	47	44	Type A	0,92
40*	SUCF 208	681552		83	110	11	26	19	-	36	44	44	Type A	0,85
Eccentric collar shaft locking • Version with bearing Type D														
40*	SHCF 208	62349		83	110	11	26	19	-	36	51,7	44	Type D	1,04

Item code for order = B0000 + Code

* = Version with special fixing holes.

¹⁾ = Solid flange.

• = Solid flange 19,5.

Packaging: 4 pieces.

Square flange bearing units

UCFS/C - SUCFS/C - HCFS/C - SHCFS/C



- Austenitic stainless steel surface
- Waterproof housing
- Grub screws or eccentric collar shaft locking
- Solid flange
- Closed surface structure.

Material

- Housing in reinforced polyamide PA FV resin (black)
- Austenitic stainless steel surface
- Protection cover in polypropylene PP (orange)
- Seal and O-Ring in NBR rubber (black)
- Ball type nickel plated brass greasing nipple.

Continuous operating temperature

in air: - 20 to + 60°C.

Maximum allowed misalignment: 2°.

Bearing



- Type A (grub screws shaft locking)
- Type D (eccentric collar shaft locking)
- Chrome alloy steel
- Superagriseal unit
- Prelubricated with lithium / calcium grease
- Can be relubricated.

• Series UCFS/C • Type A
Grub screws shaft locking

• Series HCFS/C • Type D
Eccentric collar shaft locking

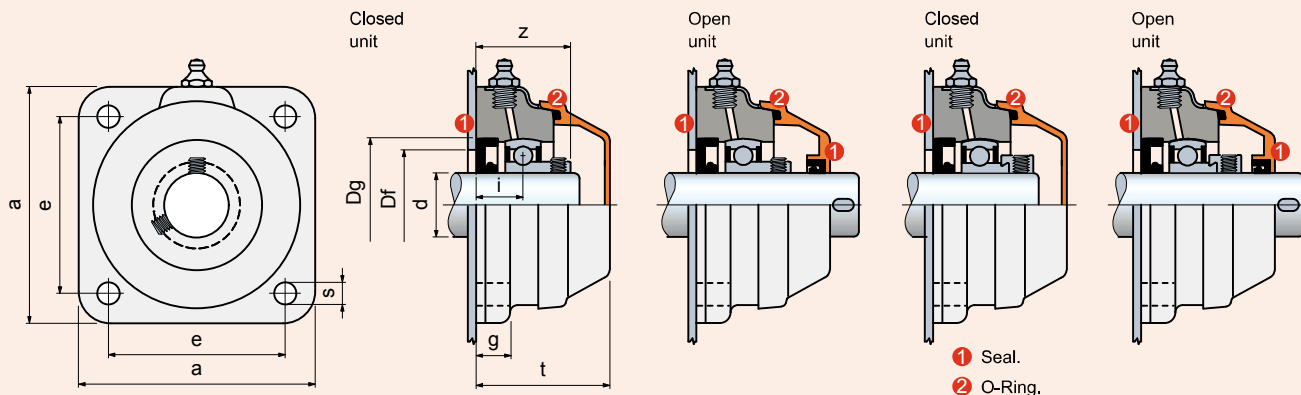

UCFS/C - SUCFS/C - HCFS/C - SHCFS/C

dia. d mm	Series	Housing material		Dimensions in mm								Bore in frame ¹⁾ Df		Bearing	Spare parts Cover orange	
		Polyamide PA FV with austenitic stainless steel surface Solid Flange Cover (orange)	Code	e	a	s	g	i	z	t	Dg	max.	min.		Weight Kg	Code
Grub screws shaft locking • Closed unit																
30	UCFS 206 C	647613	83	111	10,5	15,9	22	44	65,8	62	60	50	Type A	0,73	63539	
35*	SUCFS 207 C	647623	83	111	10,5	15,9	22	45,5	65,8	72	70	55	Type A	0,84	63539	
40*	SUCFS 208 C	647633	83	111	10,5	15,9	22	47	65,8	80	78	65	Type A	0,94	63539	
Grub screws shaft locking • Open unit																
30	UCFS 206 C	647643	83	111	10,5	15,9	22	44	65,8	62	60	50	Type A	0,73	615682	
35*	SUCFS 207 C	647653	83	111	10,5	15,9	22	45,5	65,8	72	70	55	Type A	0,84	615692	
40*	SUCFS 208 C	647663	83	111	10,5	15,9	22	47	65,8	80	78	65	Type A	0,94	63549	
Eccentric collar shaft locking • Closed unit																
40*	SHCFS 208 C	647693	83	111	10,5	15,9	19	51,7	65,8	80	78	65	Type D	1,00	63539	
Eccentric collar shaft locking • Open unit																
40*	SHCFS 208 C	647723	83	111	10,5	15,9	19	51,7	65,8	80	78	65	Type D	1,00	63549	

* = Version with special fixing holes.

¹⁾ = Dimensions Df max / Df min must be respected to ensure positive retention of the seals and to allow air bleeding during lubrication.

Packaging: 4 pieces.

Square flange bearing units

F - SF



Waterproof housing

Shaft shoulders locking

High axial load capacity.

PA FV polyamide housing

High mechanical and heat resistance. Proof to dust, humidity, washouts, steam, average aggressive chemical agents.

Material

PA FV polyamide housing

- Housing in reinforced polyamide PA FV resin (black)
- Seal and O-Ring in NBR rubber (black)
- Ball type nickel plated brass greasing nipple
- Reinforcing bushings on mounting holes and washers in stainless steel AISI 304.

Continuous operating temperature

in air: - 20 to + 60°C.

Maximum allowed misalignment: 2°.

Bearing

- Type 1200 self aligning ball bearing
- Chrome alloy steel
- Supplied without grease
- To be prelubricated with lithium / calcium grease during first installation.

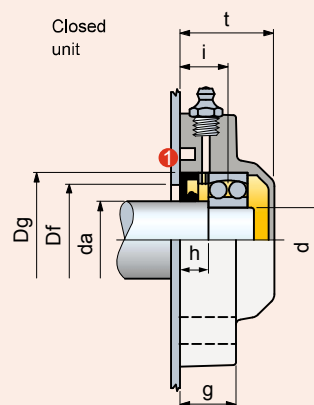
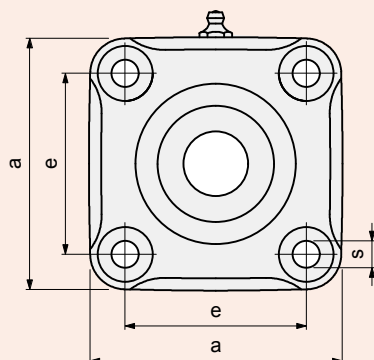

Open unit

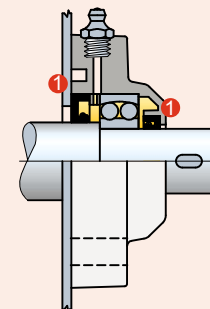

1 Seal.

Shaft dia. da mm	Bearing dia. d mm	Series	Housing material		Dimensions in mm								Bore in frame ¹⁾ Df		Bearing	Weight Kg
			Polyamide PA FV Standard Flange (black)	Code	e	a	s	g	i	h	t	Dg	max.	min.		
Closed unit																
30	25	F 1205	Polyamide PA FV Standard Flange (black)	64433	70	98	11	22,5	18,5	11	36,5	52	50	47	Type 1200	0,36
Open unit																
30	25	F 1205	Polyamide PA FV Standard Flange (black)	64483	70	98	11	22,5	18,5	11	36,5	52	50	47	Type 1200	0,36

Item code for order = B0000 + Code

¹⁾ = Dimensions Df max / Df min must be respected to ensure positive retention of the seals and to allow air bleeding during lubrication.

Packaging: 6 pieces.

Oval flange bearing units

UCFLN/C - SUCFLN/C - HCFLN/C - SHCFLN/C



Waterproof housing

Grub screws or eccentric collar shaft locking

PA FV polyamide housing

High mechanical and heat resistance. Proof to dust, humidity, washouts, steam, average aggressive chemical agents.

Solid flange bearings

Closed surface structure, ideal for sanification.

Material

PA FV polyamide housing

- Housing in reinforced polyamide PA FV resin (black)
- Protection cover in polypropylene PP (orange)
- Seal and O-Ring in NBR rubber (black)
- Ball type nickel plated brass greasing nipple
- Reinforcing bushings on mounting holes and washers in stainless steel AISI 304

Continuous operating temperature

in air: - 20 to + 60°C.

Maximum allowed misalignment: 2°.

Bearing



- Type A (grub screws shaft locking)
- Chrome alloy steel
- Superagriseal unit
- Prelubricated with lithium / calcium grease
- Can be relubricated.

• Series UCFLN/C • Type A Grub screws shaft locking

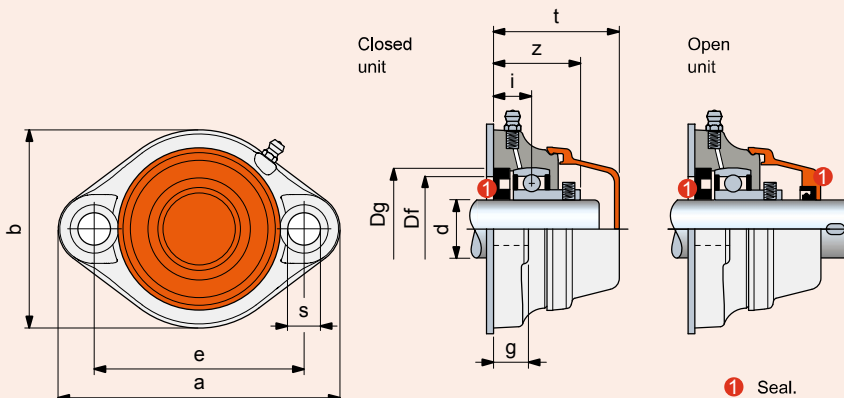

1 Seal.

UCFLN/C - SUCFLN/C - HCFLN/C - SHCFLN/C

dia. d mm	Series	Housing material		Dimensions in mm										Bore in frame ¹⁾ Df		Bearing	Spare parts Cover orange	
		Polyamide PA FV Solid Flange (black) Cover (orange)	Code	e	a	b	s	g	i	z	t	Dg	max.	min.	Weight Kg		Code	
Grub screws shaft locking • Closed unit																		
30*	SUCFLN 206 C	625933	90	122	85	11	15	15	37	54	62	60	50	Type A	0,37	626203		
Grub screws shaft locking • Open unit																		
30*	SUCFLN 206 C	625953	90	122	85	11	15	15	37	54	62	60	50	Type A	0,37	626223		

* = Version with special fixing holes.

¹⁾ = Dimensions Df max / Df min must be respected to ensure positive retention of the seals and to allow air bleeding during lubrication.

Packaging: 4 pieces.

Oval flange bearing units

UCFLN - SUCFLN - HCFLN - SHCFLN



Accessories

- Material**
PA FV polyamide housing
 - Housing in reinforced polyamide PA FV resin (black)
 - Ball type nickel plated brass greasing nipple
 - Reinforcing bushings on mounting holes and washers in stainless steel AISI 304.
- Continuous operating temperature**
 in air: - 20 to + 60°C.
- Maximum allowed misalignment:** 2°.
- Bearing**
 - Type B (grub screws shaft locking, chrome alloy steel, Supergriseal unit plus centrifuging ring)
 - Type C (grub screws shaft locking, stainless steel AISI 420, Supergriseal unit plus rubberised centrifuging ring)
 - Type A (grub screws shaft locking, chrome alloy steel, Supergriseal unit)
 - Prelubricated with lithium / calcium grease
 - Can be relubricated.

Grub screws or eccentric collar shaft locking

Version with bearing Type B

The double ring guarantees maximum protection against dust and non-corrosive substances.

Version with stainless steel bearing Type C

AISI 420 stainless steel bearing with 2 rubberised rings, provides excellent seal against humidity, steams, liquids, medium corrosive chemical agents. Maximum load ability is inferior.

Version with bearing Type A

The rubberised ring guarantees maximum protection against dusts.

Material

Polyamide PA FV guarantees maximum strength and high-temperature resistance.

Protection covers (accessories)

Closed cover

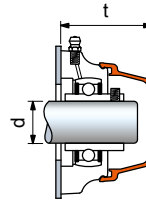

dia. d mm	Accessories	t mm	
	Cover orange Code	UCFL	HCFL
Closed cover supplied			
30	63154	55	55
Open cover supplied with seals			
30*	626203/626223	54	54

Open cover

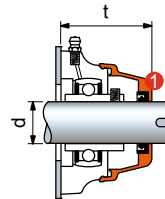

1 Seals.

* = Version with special fixing holes.

• Series UCFLN • Type B
Grub screws shaft locking

• Series UCFLN • Type C
Grub screws shaft locking

• Series UCFLN • Type A
Grub screws shaft locking

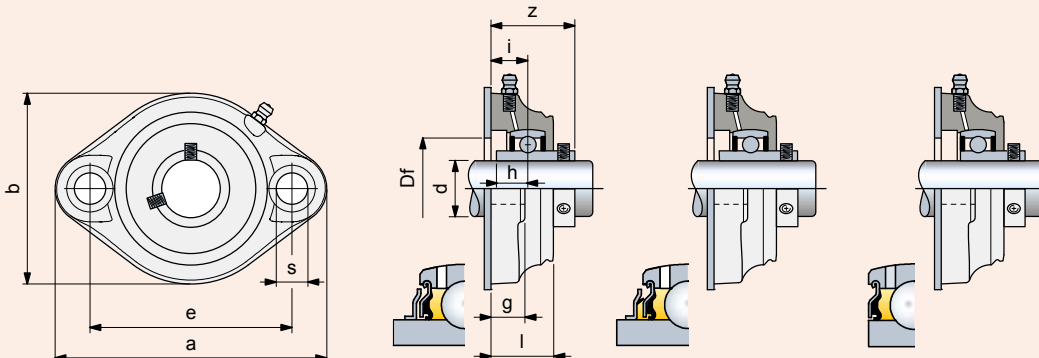

UCFLN - SUCFLN - HCFLN - SHCFLN

dia. d mm	Series	Housing material		Dimensions in mm										Bore in frame Df mm	Bearing	Weight Kg
		Polyamide PA FV Solid Flange (black)	Code	e	a	b	s	g	i	h	l	z				
Grub screws shaft locking • Version with bearing Type B																
30*	SUCFLN 206	633603		90	122	85	11	15	15	15,9	28	37,2	45	Type B	0,29	
Grub screws shaft locking • Version with stainless steel bearing Type C																
30*	SUCFLN 206	633643		90	122	85	11	15	15	15,9	28	37,2	45	Type C	0,29	
Grub screws shaft locking • Version with bearing Type A																
30*	SUCFLN 206	633693		90	122	85	11	15	15	-	28	37	34	Type A	0,29	

Item code for order = B0000 + Code

* = Version with special fixing holes.

Packaging: 4 pieces.

Oval flange bearing units

UCFL/C - SUCFL/C - HCFL/C - SHCFL/C



Waterproof housing

Grub screws or eccentric collar shaft locking

PA FV polyamide housing

High mechanical and heat resistance. Proof to dust, humidity, washouts, steam, average aggressive chemical agents.

Solid flange bearings

They differ from standard flange versions for their closed surface structure, ideal for sanitation.

Material

PA FV polyamide housing

- Housing in reinforced polyamide PA FV resin (black)
- Protection cover in polypropylene PP (orange)
- Seal and O-Ring in NBR rubber (black)
- Ball type nickel plated brass greasing nipple
- Reinforcing bushings on mounting holes and washers in stainless steel AISI 304

Continuous operating temperature

in air: - 20 to + 60°C.

Maximum allowed misalignment: 2°.

Bearing



- Type A (grub screws shaft locking)
- Type D (eccentric collar shaft locking)
- Chrome alloy steel
- Superagriseal unit
- Prelubricated with lithium / calcium grease
- Can be relubricated.

• Series UCFL/C • Type A Grub screws shaft locking

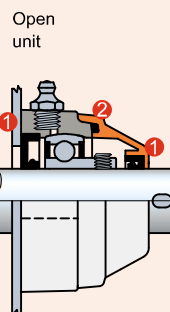
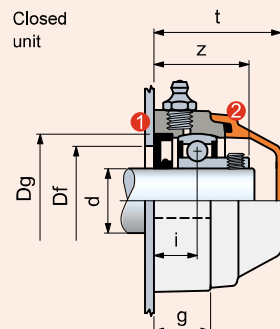

• Series HCFL/C • Type D Eccentric collar shaft locking

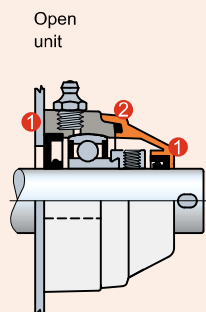
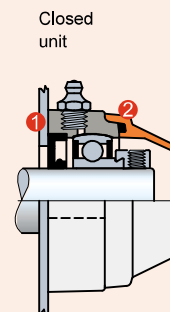

1 Seal.

2 O-Ring.

3 Only for series 206

UCFL/C - SUCFL/C - HCFL/C - SHCFL/C

dia. d mm	Series	Housing material		Dimensions in mm										Bore in frame ²⁾ Df		Bearing	Weight Kg	Spare parts Cover orange	
		Polyamide PA FV Standard Flange (black) Cover (orange)	Code	e	a	b	s	g	i	z	t	Dg	max.	min.	Code			Code	
Grub screws shaft locking • Closed unit																			
20	UCFL 204 C	69016		90	116	62	11	20	15,2	33,2	46	47	45	40	Type A	0,25	681942		
25	UCFL 205 C	68523		99	130	71	11	22,5	16,8	36,3	49,5	52	50	45	Type A	0,33	681952		
30	UCFL 206 C	68399		117	148	85	11	26	20	42	56	62	60	50	Type A	0,42	63154		
35	UCFL 207 C	648131		130	162	93	11	26	19,5	43	59	72	70	55	Type A	0,65	682022		
40	UCFL 208 C	672411		144	176	102	11	30	22	47	65,5	80	78	65	Type A	0,90	63539		
40*	SUCFL 208 C	697712¹⁾		117	148	112	11	26	19	44	62	80	78	65	Type A	0,74	63539		
Grub screws shaft locking • Open unit																			
20	UCFL 204 C	69026		90	116	62	11	20	15,2	33,2	46	47	45	40	Type A	0,25	681962		
25	UCFL 205 C	68533		99	130	71	11	22,5	16,8	36,3	49,5	52	50	45	Type A	0,33	681972		
30	UCFL 206 C	68409		117	148	85	11	26	20	42	56	62	60	50	Type A	0,42	69965		
35	UCFL 207 C	648141		130	162	93	11	26	19,5	43	59	72	70	55	Type A	0,65	682032		
40	UCFL 208 C	672421		144	176	102	11	30	22	47	65,5	80	78	65	Type A	0,90	63549		
40*	SUCFL 208 C	697732¹⁾		117	148	112	11	26	19	44	62	80	78	65	Type A	0,74	63549		
Eccentric collar shaft locking • Closed unit																			
40*	SHCFL 208 C	697752¹⁾		117	148	112	11	26	19	51,7	68	80	78	65	Type D	0,93	600882		
Eccentric collar shaft locking • Open unit																			
40*	SHCFL 208 C	697772		117	148	112	11	26	19	51,7	68	80	78	65	Type D	0,93	600892		

* = Version with special fixing holes.

SUCFL206C/SHCFL206C: Assembly with cylindrical head screws.

¹⁾ = Solid flange.

²⁾ = Dimensions Df max / Df min must be respected to ensure positive retention of the seals and to allow air bleeding during lubrication.

Packaging: 4 pieces.

Oval flange bearing units

UCFL - SUCFL - HCFL - SHCFL



Accessories

Material

PA FV polyamide housing

- Housing in reinforced polyamide PA FV resin (black)
- Ball type nickel plated brass greasing nipple
- Reinforcing bushings on mounting holes and washers in stainless steel AISI 304.

Continuous operating temperature

in air: - 20 to + 60°C.

Maximum allowed misalignment: 2°.

Bearing

- Type B (grub screws shaft locking, chrome alloy steel, Superagriseal unit plus centrifuging ring)
- Type C (grub screws shaft locking, stainless steel AISI 420, Superagriseal unit plus rubberised centrifuging ring)
- Type A (grub screws shaft locking, chrome alloy steel, Superagriseal unit)
- Type D (eccentric collar shaft locking, chrome alloy steel, Superagriseal unit)
- Prelubricated with lithium / calcium grease
- Can be relubricated.

Grub screws or eccentric collar shaft locking

Version with bearing Type B

The double ring guarantees maximum protection against dust and non-corrosive substances.

Version with stainless steel bearing Type C

AISI 420 stainless steel bearing with 2 rubberised rings, provides excellent seal against humidity, steams, liquids, medium corrosive chemical agents. Maximum load ability is inferior.

Version with bearing Type A

The rubberised ring guarantees maximum protection against dusts.

Material

Polyamide PA FV guarantees maximum strength and high-temperature resistance.

Protection covers (accessories)

Closed cover

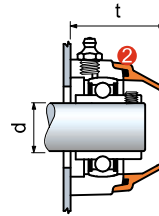

Open cover

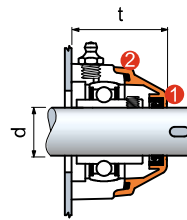

dia. d mm	Accessories Cover orange		t mm	
	Code	UCFL	HCFL	
Closed cover supplied with seals				
17*	681942	46	49	
20	681942	46	49	
25	681952	49,5	49,5	
25*	681952	49,5	49,5	
30	63154	55	55	
30*	63154	55	55	
35	682022	59	59	
40 ²⁾	600882	-	71	
Open cover supplied with seals				
17*	696162	46	49	
25	681972	49,5	49,5	
25*	681972	49,5	49,5	
30	69965	55	55	
30*	69965	55	55	
35	682032	59	59	
35*	615692	62	62	
40 ¹⁾	63549	65,5	-	

- ① Seals.
- ② Seals O-Ring.
- ③ Only for series 206

* = Version with special fixing holes.

¹⁾ = Protection cover for bearing unit with grub screws shaft locking.

²⁾ = Protection cover for bearing unit with eccentric collar shaft locking.

• Series UCFL • Type B
Grub screws shaft locking

• Series UCFL • Type C
Grub screws shaft locking

• Series UCFL • Type A
Grub screws shaft locking

• Series HCFL • Type D
Eccentric collar shaft locking

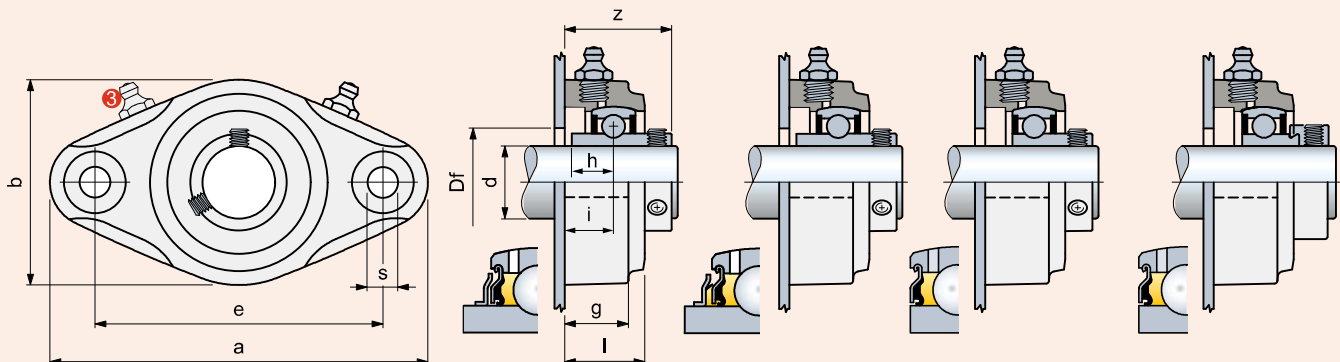

UCFL - SUCFL - HCFL - SHCFL

dia. d mm	Series	Housing material		Dimensions in mm										Bore in frame Df mm	Bearing	Weight Kg
		Polyamide PA FV Standard Flange (black)	Code	e	a	b	s	g	i	h	l	z				
Grub screws shaft locking • Version with bearing Type B																
20	UCFL 204	69056		90	116	62	11	20	15,2	12,7	25	33,5	24	Type B	0,25	
25	UCFL 205	68563		99	130	71	11	22,5	16,8	14,3	27,5	36,5	29	Type B	0,31	
30	UCFL 206	68439		117	148	85	11	26	19	15,9	32,5	42,2	34	Type B	0,44	
Grub screws shaft locking • Version with stainless steel bearing Type C																
20	UCFL 204	646542		90	116	62	11	20	15,2	12,7	25	33,5	24	Type C	0,25	
25	UCFL 205	646552		99	130	71	11	22,5	16,8	14,3	27,5	36,6	29	Type C	0,31	
30	UCFL 206	646562		117	148	85	11	26	19	15,9	32,5	42,2	34	Type C	0,44	
Grub screws shaft locking • Version with bearing Type A																
20	UCFL 204	655482		90	116	62	11	20	15,2	-	25	33,2	24	Type A	0,23	
25	UCFL 205	655472		99	130	71	11	22,5	16,8	-	27,5	36,3	29	Type A	0,31	
30	UCFL 206	666412		117	148	85	11	26	20	-	32,5	42	34	Type A	0,39	
40*	SUCFL 208	602193 ¹⁾		117	148	112	11	26	19	-	33	44	44	Type A	0,91	
Eccentric collar shaft locking • Version with bearing Type D																
40*	SHCFL 208	602213 ¹⁾		117	148	112	11	26	19	-	33	51,7	44	Type D	0,91	

* = Version with special fixing holes.

SUCFL/SHCFL: Assembly with cylindrical head screws.

¹⁾ = Solid flange.

Packaging: 4 pieces.

Pillow block type bearing units

UCP/C - HCP/C



Waterproof housing

Grub screws or eccentric collar shaft locking

PA FV polyamide housing

High mechanical and heat resistance. Proof to dust, humidity, washouts, steam, average aggressive chemical agents.

PP FV polypropylene housing

Proof to highly aggressive chemical agents. Inferior loading ability.

Material

PA FV polyamide housing

- Housing in reinforced polyamide PA FV resin (black)
- Protection cover in polypropylene PP (orange)
- Seal and O-Ring in NBR rubber (black)
- Ball type nickel plated brass greasing nipple
- Reinforcing bushings on mounting holes and washers in stainless steel AISI 304
- Stainless steel AISI 303 safety ring.

Continuous operating temperature

in air: - 20 to + 60°C.

Maximum allowed misalignment: 2°.

Bearing



- Type A (grub screws shaft locking)
- Type D (eccentric collar shaft locking)
- Chrome alloy steel
- Supergriseal unit
- Prelubricated with lithium / calcium grease
- Can be relubricated.

• Series UCP/C • Type A Grub screws shaft locking

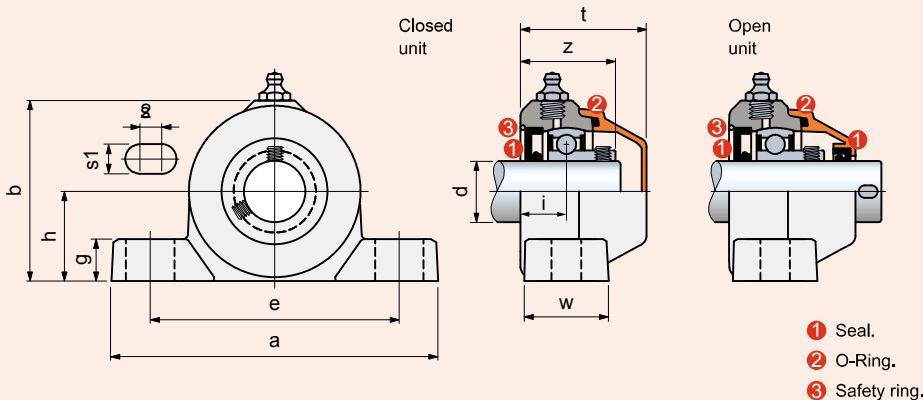

dia. d mm	Series	Housing material		Dimensions in mm												Bearing	Weight Kg	Spare parts Cover orange	
		Polyamide PA FV Flange (black) Cover (orange)	Code	e	a	h	b	s1	s2	g	w	i	z	t	Code			Code	
Grub screws shaft locking • Closed unit																			
20	UCP 204 C	682941	96	128	33,3	67	12	10	17	30	18,9	36,9	49,7	Type A	0,27	681942			
25	UCP 205 C	646511	106	140	36,5	75	12	10	17	34,5	18,8	38,3	51,5	Type A	0,33	681952			
Grub screws shaft locking • Open unit																			
20	UCP 204 C	682931	96	128	33,3	67	12	10	17	30	18,9	36,9	49,7	Type A	0,27	681962			
25	UCP 205 C	646521	106	140	36,5	75	12	10	17	34,5	18,8	38,3	51,5	Type A	0,33	681972			

Packaging: 4 pieces.

Pillow block type bearing units

UCP - HCP



Accessories

Material

PA FV polyamide housing

- Housing in reinforced polyamide PA FV resin (black)
- Ball type nickel plated brass greasing nipple
- Reinforcing bushings on mounting holes and washers in stainless steel AISI 304.

Continuous operating temperature

in air: - 20 to + 60°C.

Maximum allowed misalignment: 2°.

Bearing

- Type B (grub screws shaft locking, chrome alloy steel, Superagriseal unit plus centrifuging ring)
- Type C (grub screws shaft locking, stainless steel AISI 420, Superagriseal unit plus rubberised centrifuging ring)
- Type A (grub screws shaft locking, chrome alloy steel, Superagriseal unit)
- Type D (eccentric collar shaft locking, chrome alloy steel, Superagriseal unit)
- Prelubricated with lithium / calcium grease
- Can be relubricated.

Grub screws or eccentric collar shaft locking

Version with bearing Type B

The double ring guarantees maximum protection against dust and non-corrosive substances.

Version with stainless steel bearing Type C

AISI 420 stainless steel bearing with 2 rubberised rings, provides excellent seal against humidity, steams, liquids, medium corrosive chemical agents. Maximum load ability is inferior.

Version with bearing Type A

The rubberised ring guarantees maximum protection against dusts.

Material

Polyamide PA FV guarantees maximum strength and high-temperature resistance.

Protection covers (accessories)

Closed cover

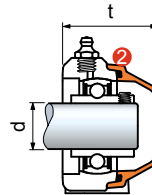

Open cover

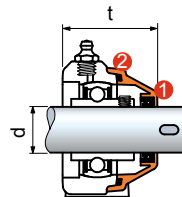

1 Seals.

2 Seals O-Ring.

dia. d mm	Accessories	t mm	
	Cover orange Code	UCFL	HCFL
Closed cover supplied with seals			
20	681942	49,7	52
25	681952	51,5	51,5
30	63154	55	55
35	682022	61	61
40 ²⁾	600882	-	72
Open cover supplied with seals			
25	681972	51,5	51,5
30	69965	55	55
35	682032	61	61
40 ¹⁾	63549	66,5	-

¹⁾ = Protection cover for bearing unit with grub screws shaft locking.

²⁾ = Protection cover for bearing unit with eccentric collar shaft locking.

• Series UCP • Type B
Grub screws shaft
locking

• Series UCP • Type C
Grub screws shaft
locking

• Series UCP • Type A
Grub screws shaft
locking

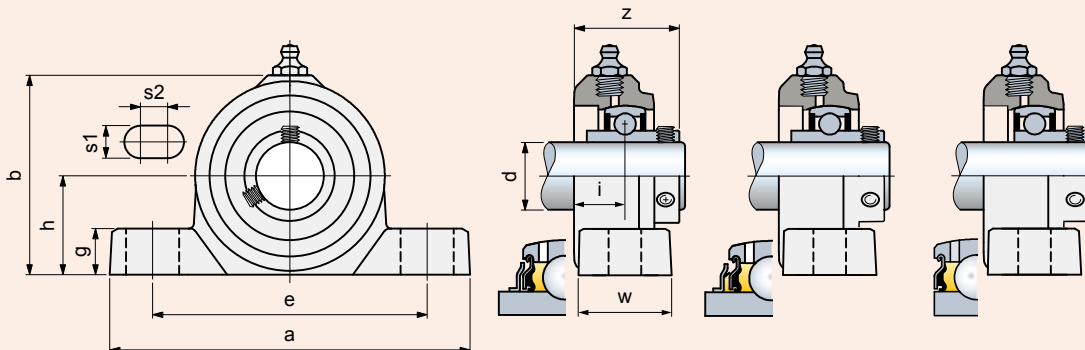

dia. d mm	Series	Housing material	Dimensions in mm											Bearing	Weight Kg
		Polyamide PA FV Flange (black)	e	a	h	b	s1	s2	g	w	i	z			
		Code													
Grub screws shaft locking • Version with bearing Type B															
25	UCP 205	648781	106	140	36,5	75	12	10	17	34,5	18,8	38,5	Type B	0,33	
Grub screws shaft locking • Version with stainless steel bearing Type C															
25	UCP 205	646502	106	140	36,5	75	12	10	17	34,5	18,8	38,6	Type C	0,33	
Grub screws shaft locking • Version with bearing Type A															
25	UCP 205	678562	106	140	36,5	75	12	10	17	34,5	18,8	38,3	Type A	0,30	

Packaging: 4 pieces.

Compact pillow block

UCPA/C - HCPA/C



Waterproof housing

Grub screws or eccentric collar shaft locking

PA FV polyamide housing

High mechanical and heat resistance. Proof to dust, humidity, washouts, steam, average aggressive chemical agents.

Material

PA FV polyamide housing

- Housing in reinforced polyamide PA FV resin (black)
- Protection cover in polypropylene PP (orange)
- Seal and O-Ring in NBR rubber (black)
- Ball type nickel plated brass greasing nipple
- Nickel plated brass threaded bushings.

Continuous operating temperature

in air: - 20 to + 60°C.

Maximum allowed misalignment: 2°.

Bearing



- Type A (grub screws shaft locking)
- Chrome alloy steel
- Superagriseal unit
- Prelubricated with lithium / calcium grease
- Can be relubricated.

• Series UCPA/C • Type A Grub screws shaft locking

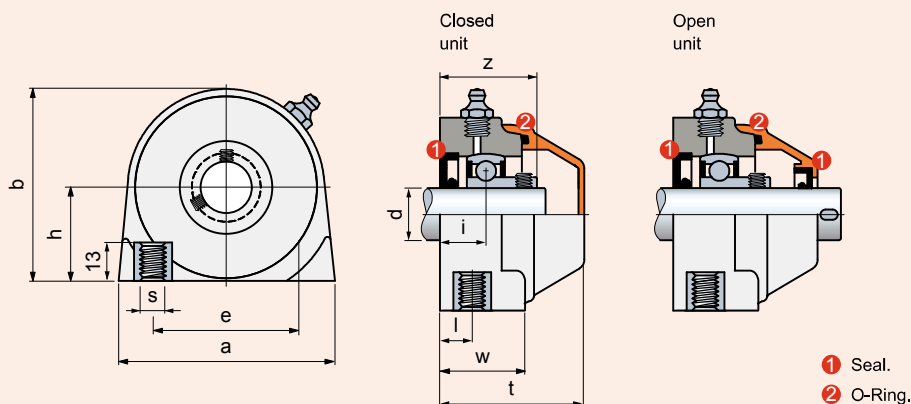

dia. d mm	Series	Housing material		Dimensions in mm											Bearing	Weight Kg	Spare parts Cover orange	
		Polyamide PA FV Flange (black) Cover (orange)	Code	e	a	h	b	s	w	i	l	z	t	Code				
Grub screws shaft locking • Closed unit																		
25	UCPA 205 C	696202		50,8	75	36,5	72	M10	30	16,8	12	36,3	52	Type A	0,29	681952		
Grub screws shaft locking • Open unit																		
25	UCPA 205 C	696232		50,8	75	36,5	72	M10	30	16,8	12	36,3	52	Type A	0,29	681972		

Packaging: 4 pieces.

Side flange bearing units

UCFB/C - HCFB/C



The picture shows
d. 20 - 25 version.

For other versions please
see the technical drawing.

Waterproof housing

Grub screws or eccentric collar shaft locking

PA FV polyamide housing

High mechanical and heat resistance. Proof to dust, humidity, washouts, steam, average aggressive chemical agents.

Solid flange bearings

They differ from standard flange versions for their closed surface structure, ideal for sanification.

Material

PA FV polyamide housing

- Housing in reinforced polyamide PA FV resin (black)
- Protection cover in polypropylene PP (orange)
- Seal and O-Ring in NBR rubber (black)
- Ball type nickel plated brass greasing nipple
- Reinforcing bushings on mounting holes and washers in stainless steel AISI 304

Continuous operating temperature

in air: - 20 to + 60°C.

Maximum allowed misalignment: 2°.

Bearing



- Type A (grub screws shaft locking)
- Chrome alloy steel
- Superagriseal unit
- Prelubricated with lithium / calcium grease
- Can be relubricated.

• Series UCFB/C • Type A Grub screws shaft locking

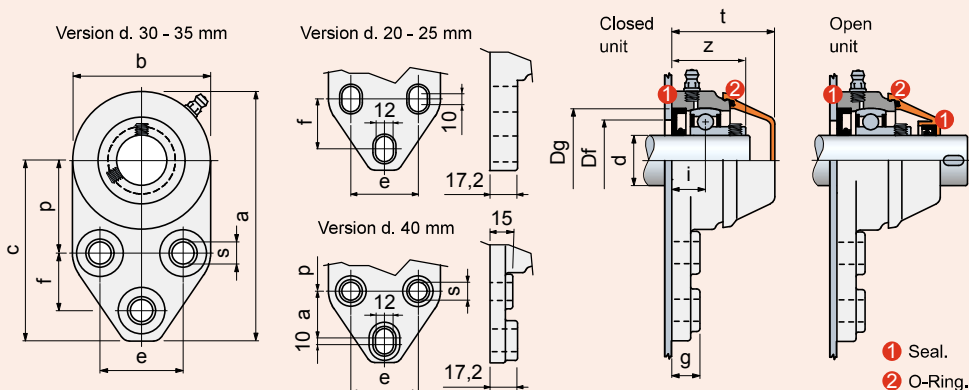

		Housing material																				
		Polyamide PA FV Standard Flange (black) Cover (orange)																				
dia. d mm	Series	Code	Dimensions in mm															Bore in frame ¹⁾ Df		Bearing	Weight Kg	Spare parts Cover orange Code
			a	b	c	p	e	f	s	g	i	z	t	Dg	max.	min.						
Grub screws shaft locking • Closed unit																						
25	UCFB 205 C	656542N	124,2	68,8	89,8	46	41,3	28,6	11	17,2	17,8	37,3	52	52	50	45	Type A	0,32	681952			
30	UCFB 206 C	656562	138,6	81,3	97,9	52,4	47,6	31,7	11	14	20	42	55	62	60	50	Type A	0,47	63154			
Grub screws shaft locking • Open unit																						
25	UCFB 205 C	656552N	124,2	68,8	89,8	46	41,3	28,6	11	17,2	17,8	37,3	52	52	50	45	Type A	0,32	681972			
30	UCFB 206 C	656572	138,6	81,3	97,9	52,4	47,6	31,7	11	14	20	42	55	62	60	50	Type A	0,47	69965			

¹⁾ = Dimensions Df max / Df min must be respected to ensure positive retention of the seals and to allow air bleeding during lubrication.
Packaging: 4 pieces.

Side flange bearing units

UCFB - HCFB



The picture shows
d. 20 - 25 version.

For other versions please
see the technical drawing.



Accessories

- **Material**
PA FV polyamide housing
 - Housing in reinforced polyamide PA FV resin (black)
 - Ball type nickel plated brass greasing nipple
 - Reinforcing bushings on mounting holes in stainless steel AISI 304.
- **Continuous operating temperature**
in air: - 20 to + 60°C.
- **Maximum allowed misalignment: 2°.**
- **Bearing**
 - Type B (grub screws shaft locking, chrome alloy steel, Superagriseal unit plus centrifuging ring)
 - Type C (grub screws shaft locking, stainless steel AISI 420, Superagriseal unit plus rubberised centrifuging ring)
 - Type A (grub screws shaft locking, chrome alloy steel, Superagriseal unit)
 - Prelubricated with lithium / calcium grease
 - Can be relubricated.

Grub screws or eccentric collar shaft locking

Version with bearing Type B

The double ring guarantees maximum protection against dust and non-corrosive substances.

Version with stainless steel bearing Type C

AISI 420 stainless steel bearing with 2 rubberised rings, provides excellent seal against humidity, steams, liquids, medium corrosive chemical agents. Maximum load ability is inferior.

Version with bearing Type A

The rubberised ring guarantees maximum protection against dusts.

Material

Polyamide PA FV guarantees maximum strength and high-temperature resistance.

Protection covers (accessories)

Closed cover

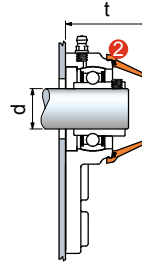

Open cover

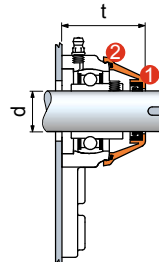

- ① Seals.
- ② Seals O-Ring.

dia. d mm	Accessories Cover orange	t mm	
	Code	UCFL	HCFL
Closed cover supplied with seals			
20	681942	49	49
25	681952	52	57
30	63154	55	60
35	682022	59	64,5
40	600882	72	72
Open cover supplied with seals			
25	681972	52	57
30	69965	55	60
35	682032	59	64,5

• Series UCFB • Type B Grub screws shaft locking

• Series UCFB • Type C Grub screws shaft locking

• Series UCFB • Type A Grub screws shaft locking

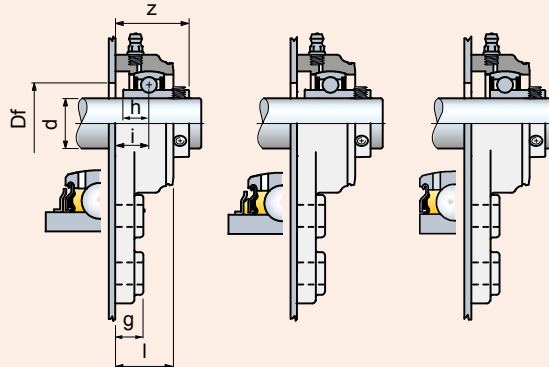
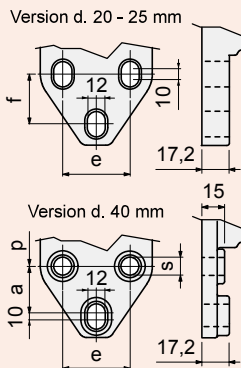
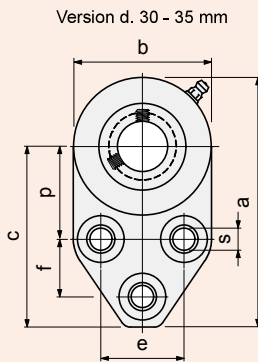

dia. d mm	Series	Housing material	Dimensions in mm													Bore in frame Df mm	Bearing	Weight Kg
		Polyamide PA FV Solid Flange (black) Code	a	b	c	p	e	f	s	g	i	h	l	z				
Grub screws shaft locking • Version with bearing Type B																		
25	UCFB 205	663912N	124,2	68,8	89,8	46	41,3	28,6	11	17,2	17,8	14,3	29	37,5	29	Type B	0,33	
30	UCFB 206	663922	138,6	81,3	97,9	52,4	47,6	31,7	11	14	20	15,9	31,5	42,2	34	Type B	0,50	
Grub screws shaft locking • Version with stainless steel bearing Type C																		
25	UCFB 205	663942N	124,2	68,8	89,8	46	41,3	28,6	11	17,2	17,8	14,3	29	37,6	29	Type C	0,33	
30	UCFB 206	663952	138,6	81,3	97,9	52,4	47,6	31,7	11	14	20	15,9	31,5	42,2	34	Type C	0,50	
Grub screws shaft locking • Version with bearing Type A																		
25	UCFB 205	663672N	124,2	68,8	89,8	46	41,3	28,6	11	17,2	17,8	-	29	37,3	29	Type A	0,30	
30	UCFB 206	663682	138,6	81,3	97,9	52,4	47,6	31,7	11	14	20	-	31,5	42	34	Type A	0,45	

Packaging: 4 pieces.

Side flange bearing units

SQL/C



Grub screws shaft locking
PP FV polypropylene housing
 Proof to highly aggressive chemical agents.
 Inferior loading ability.
Solid flange bearings
 Closed surface structure, ideal for sanification.

Material

PP FV polypropylene housing

- Housing in reinforced polypropylene PP FV resin (black)
- Protection cover in polypropylene PP (orange)
- Seal and O-Ring in NBR rubber (black)
- Ball type stainless steel AISI 316 greasing nipple
- Washers in stainless steel AISI 304.

Continuous operating temperature

in air: - 20 to + 60°C.

Maximum allowed misalignment: 2°.

Bearing



- Grub screws shaft locking
- Chrome alloy steel
- Superagriseal unit
- Prelubricated with lithium / calcium grease
- Can be relubricated.

• Series SQL/C • Type A
Grub screws shaft locking

Closed unit Right

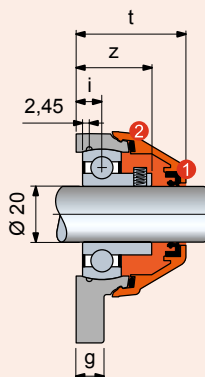
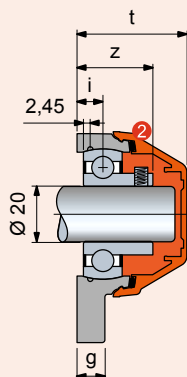
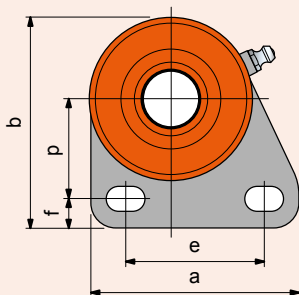

Open unit Left

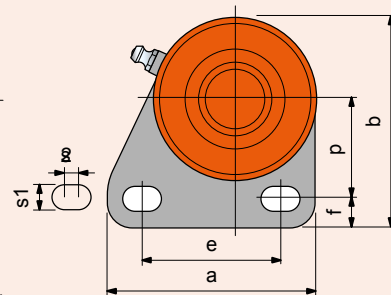

- 1 Seal.
- 2 O-Ring.

dia. d mm	Series	Housing material		Dimensions in mm											Bearing	Weight Kg	Spare parts Cover orange	
		Polypropylene PP FV Solid Flange (black) Cover (orange)	Code	e	a	b	s1	s2	g	i	z	t	f	p			Code	Code
Closed unit Left																		
20	SQL 204 C	656263		50	75	76	9	5	10	9,3	27,3	39,5	10,5	36	Type A	0,20	681942	
Open unit Left																		
20	SQL 204 C	656273		50	75	76	9	5	10	9,3	27,3	39,5	10,5	36	Type A	0,20	681962	
Closed unit Right																		
20	SQL 204 C	656283		50	75	76	9	5	10	9,3	27,3	39,5	10,5	36	Type A	0,20	681942	
Open unit Right																		
20	SQL 204 C	656293		50	75	76	9	5	10	9,3	27,3	39,5	10,5	36	Type A	0,20	681962	

Packaging: 4 pieces.

Side flange bearing units

SQL



Accessories

Grub screws shaft locking
PP FV polypropylene housing
 Proof to highly aggressive chemical agents.
 Inferior loading ability.
Solid flange bearings
 Closed surface structure, ideal for sanification.

- **Material**
PP FV polypropylene housing
 - Housing in reinforced polypropylene PP FV resin (black)
 - Ball type stainless steel AISI 316 greasing nipple
 - Washers in stainless steel AISI 304.
- **Continuous operating temperature**
 in air: - 20 to + 60°C.
- **Maximum allowed misalignment: 2°.**
- **Bearing**



- Grub screws shaft locking
- Chrome alloy steel
- Superagriseal unit
- Prelubricated with lithium / calcium grease
- Can be relubricated.

• **Series SQL • Type A**
Grub screws shaft locking

Right unit

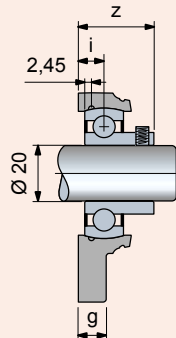
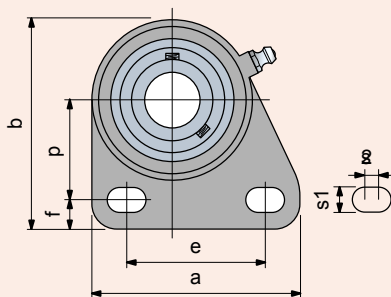

Left unit

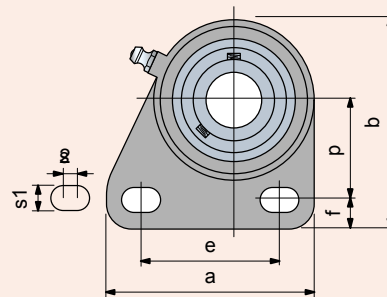

dia. d mm	Series	Housing material	Dimensions in mm											Weight Kg
		Polypropylene PP FV Solid Flange (black) Code	e	a	b	s1	s2	g	i	z	f	p	Bearing	
Left unit														
20	SQL 204	656303	50	75	76	9	5	10	9,3	27,3	10,5	36	Type A	0,18
Right unit														
20	SQL 204	656313	50	75	76	9	5	10	9,3	27,3	10,5	36	Type A	0,18

Packaging: 6 pieces.

Take-up bearing units

UCT/C - HCT/C



Waterproof housing

Grub screws or eccentric collar shaft locking

PA FV polyamide housing

High mechanical and heat resistance. Proof to dust, humidity, washouts, steam, average aggressive chemical agents.

Material

PA FV polyamide housing

- Housing in reinforced polyamide PA FV resin (black)
- Protection cover in polypropylene PP (orange)
- Seal and O-Ring in NBR rubber (black)
- Ball type nickel plated brass greasing nipple
- Threaded insert in nickel plated brass.

Continuous operating temperature

in air: - 20 to + 60°C.

Maximum allowed misalignment: 2°.

Bearing



- Type A (grub screws shaft locking)
- Chrome alloy steel
- Superagriseal unit
- Prelubricated with lithium / calcium grease
- Can be relubricated.

Assembly

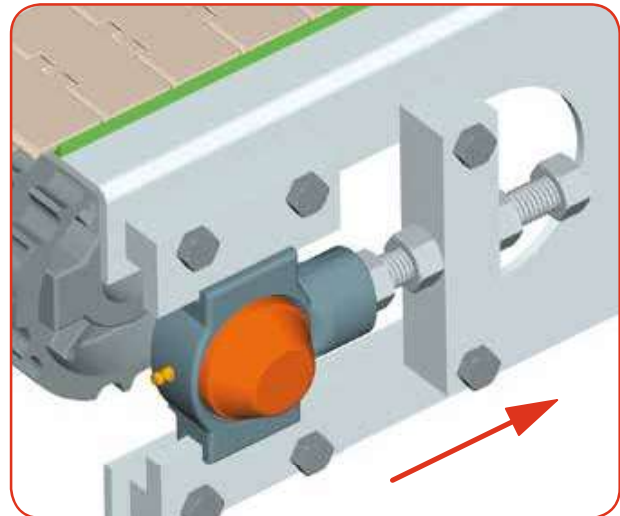

Working load allowed only in this direction.

• Series UCT/C • Type A Grub screws shaft locking

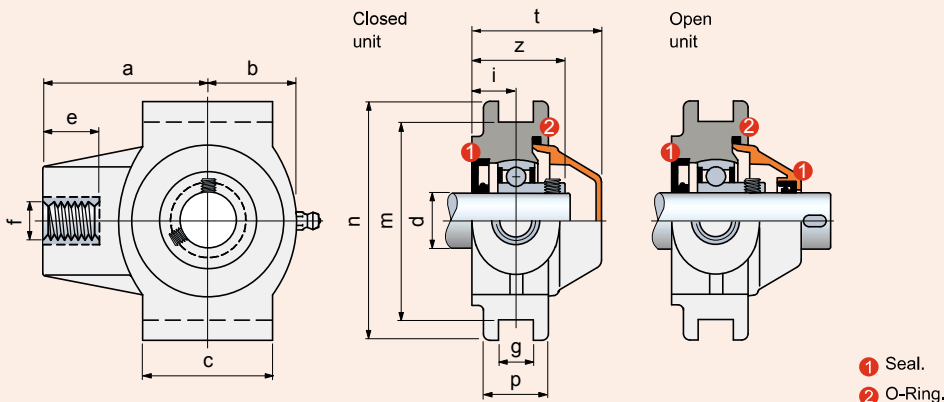

		Housing material															
		Polyamide PA FV Flange (black) Cover (orange)														Spare parts Cover orange	
dia. d mm	Series	Code	a	b	c	e	f	g	i	m	n	p	z	t	Bearing	Weight Kg	Code
Grub screws shaft locking • Closed unit																	
25	UCT 205 C	666962	68,5	39,5	50	28	M20	13,5	17	76,2	92	25	36,5	52	Type A	0,39	681872
Grub screws shaft locking • Open unit																	
25	UCT 205 C	666992	68,5	39,5	50	28	M20	13,5	17	76,2	92	25	36,5	52	Type A	0,39	681892

Packaging: 4 pieces.

Round flange bearing units

UCFC/C



Waterproof housing

Grub screws shaft locking

PA FV polyamide housing

High mechanical and heat resistance. Proof to dust, humidity, washouts, steam, average aggressive chemical agents.

Material

PA FV polyamide housing

- Housing in reinforced polyamide PA FV resin (black)
- Protection cover in polypropylene PP (orange)
- Seal and O-Ring in NBR rubber (black)
- Ball type nickel plated brass greasing nipple
- Reinforcing bushings on mounting holes and washers in stainless steel AISI 304

Continuous operating temperature

in air: - 20 to + 60°C.

Maximum allowed misalignment: 2°.

Bearing



- Type A (grub screws shaft locking)
- Chrome alloy steel
- Superagriseal unit
- Prelubricated with lithium / calcium grease
- Can be relubricated.

• Closed unit

Flange without centering ring

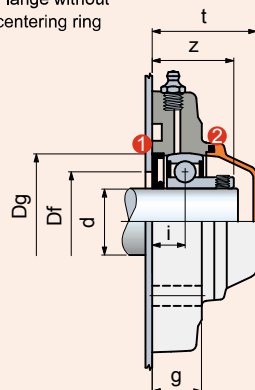
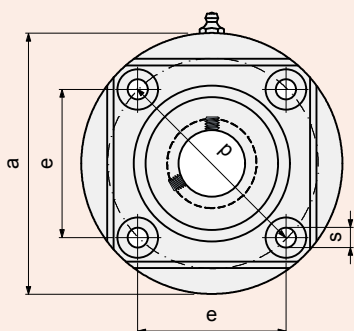

• Open unit

Flange with centering ring

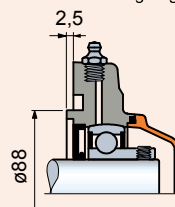

Flange without centering ring

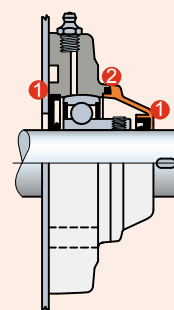

Flange with centering ring

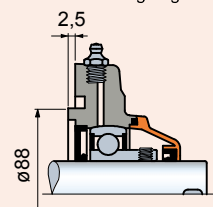

- 1 Seal.
- 2 O-Ring.

Housing material

dia. d mm	Flange	Series	Polyamide PA FV Standard Flange (black) Cover (orange)		Dimensions in mm										Bore in frame ¹⁾ Df		Bearing	Weight Kg	Spare parts Cover orange	
			Code		e	a	p	s	g	i	z	t	Dg	max.	min.	Code				
Closed unit																				
35	Without centering ring	UCFC 207 C	683921		77,8	137	110	11	26	17,3	40,8	55	72	70	55	Type A	0,75	603772		
	With centering ring	UCFC 207 C	624772		77,8	137	110	11	26	17,3	40,8	55	72	-	-	Type A	0,75	603772		
Open unit																				
35	Without centering ring	UCFC 207 C	683931		77,8	137	110	11	26	17,3	40,8	55	72	70	55	Type A	0,75	603792		
	With centering ring	UCFC 207 C	624782		77,8	137	110	11	26	17,3	40,8	55	72	-	-	Type A	0,75	603792		

¹⁾ = Dimensions Df max / Df min must be respected to ensure positive retention of the seals and to allow air bleeding during lubrication.

Packaging: 4 pieces.

Round flange bearing units

UCFC



Material

PA FV polyamide housing

- Housing in reinforced polyamide PA FV resin (black)
- Ball type nickel plated brass greasing nipple
- Reinforcing bushings on mounting holes and washers in stainless steel AISI 304.

Continuous operating temperature

in air: - 20 to + 60°C.

Maximum allowed misalignment: 2°.

Bearing

- Type B (grub screws shaft locking, chrome alloy steel, Supergriseal unit plus centrifuging ring)
- Type C (grub screws shaft locking, stainless steel AISI 420, Supergriseal unit plus rubberised centrifuging ring)
- Type A (grub screws shaft locking, chrome alloy steel, Supergriseal unit)
- Prelubricated with lithium / calcium grease
- Can be relubricated.

Grub screws shaft locking

Version with bearing Type B

The double ring guarantees maximum protection against dust and non-corrosive substances.

Version with stainless steel bearing Type C

AISI 420 stainless steel bearing with 2 rubberised rings, provides excellent seal against humidity, steams, liquids, medium corrosive chemical agents. Maximum load ability is inferior.

Version with bearing Type A

The rubberised ring guarantees maximum protection against dusts.

Material

Polyamide PA FV guarantees maximum strength and high-temperature resistance.

dia. d mm	Accessories Cover orange Code	t mm
Closed cover supplied without seals		
35	63232	50
Open cover supplied with seals		
35	604042	50

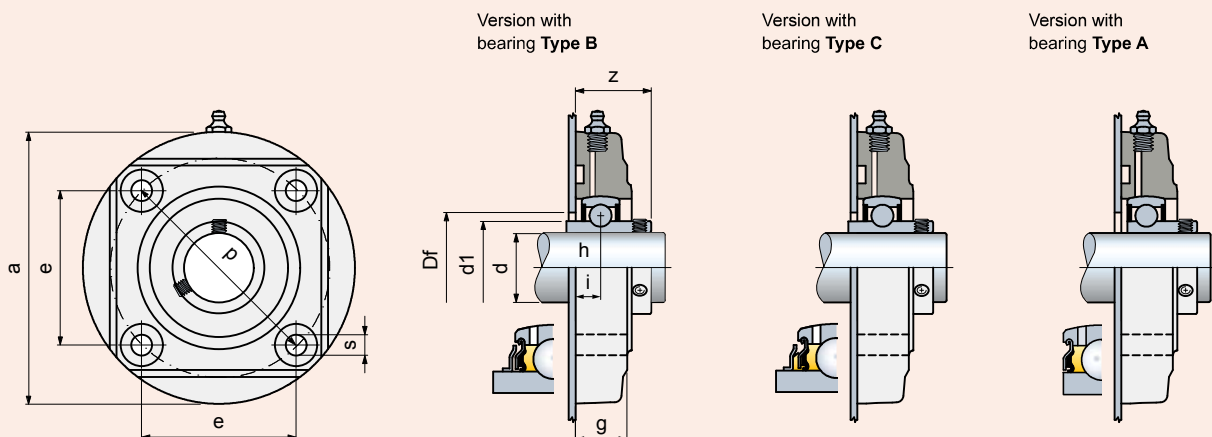

dia. d mm	Series	Housing material		Dimensions in mm									Bore in frame Df mm	Bearing	Weight Kg
		Polyamide PA FV Standard Flange (black)	Code	e	a	p	s	g	i	h	z	d1			
Version with bearing Type B															
35	UCFC 207	60752	77,8	137	110	11	26	12,3	17,5	37,7	46,1	50	Type B	0,75	
Version with stainless steel bearing Type C															
35	UCFC 207	646652	77,8	137	110	11	26	12,3	17,5	37,7	46,1	50	Type C	0,75	
Version with bearing Type A															
35	UCFC 207	681822	77,8	137	110	11	26	17,3	17,5	40,8	46,1	50	Type A	0,75	

Item code for order = B0000 + Code

Packaging: 6 pieces.

Round flange bearing units

SBF



Stainless steel AISI 304 flange

Stainless steel bearing Type C

AISI 420 stainless steel bearing with 2 rubberised rings, provides excellent seal against humidity, steams, liquids, medium corrosive chemical agents.

Load capacity

The pressed steel flanged support is suitable for light duties.

- **Material**
Pressed stainless steel AISI 304 flanges.
- **Continuous operating temperature**
in air: - 20 to + 60°C.
- **Maximum allowed misalignment:** 5°.
- **Bearing**



- Type C (grub screws shaft locking)
- stainless steel AISI 420
- Superagriseal unit plus rubberised centrifuging ring
- Prelubricated with lithium / calcium grease
- Can be relubricated.

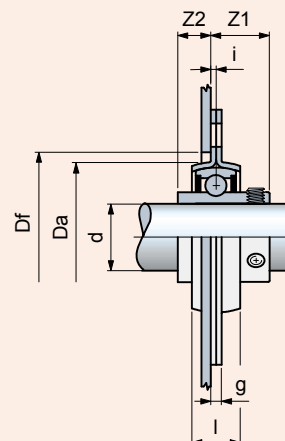
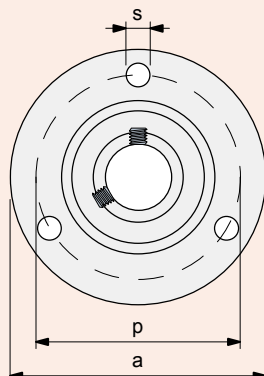

dia. d mm	Series	Housing material		Dimensions in mm									Bore in frame Df mm	Bearing	Weight Kg
		Stainless Steel AISI 304	Code	p	a	s	g	i	l	Z1	Z2	Da			
25	SBF 205	604562		76	95	8,7	4	2	18	21,8	12,3	56	60	Type C	0,35

Packaging: 4 pieces.

Technical information

Bearing unit max. static load

B68

Bearings

- Bearings with grub screw locking system B72
- Bearings with self locking eccentric collar B72
- Seals B73
- Maximum velocities B73
- Axial load capacities B73
- Self aligning ball bearings, holding by shoulders on shaft B73

Calculation data

- Definition of bearing dimensions B74
- Calculation method for self-aligning bearings B74
- Life B74
- Life expectation calculation B74
- Equivalent dynamic load calculation B75
- Static load capacity control B76
- Equivalent static load calculation B76

Lubrication

- Prelubrication B77
- Lubrication grease B77
- Relubrication B77
- Relubrication intervals B77

Grease life in bearings lubricated for life

- Formula to calculate grease life B78
- Diagram 1 grease nominal life B78
- Diagram 2 correction factor B79
- Example of calculation B79

Shaft tolerances

- Shaft tolerances for bearings with grub screws or eccentric collar locking system B80
- Shaft tolerances for bearings with shoulders type holding system B80



Mounting

- Mounting recommendations B81
- Bearing locking by grub screws B81
- Bearing locking by eccentric collar B81
- Installation/removal of covers B81

Bearing unit max. static load

UCF/C - SUCF/C - HCF/C - SHCF/C - UCF/CL - SUCF/CL
HCF/CL - SHCF/CL - UCF - SUCF - HCF - SHCF





Shaft dia. d mm				
	PA FV N	PP FV N	PA FV N	PP FV N
25	19550	13800	20700	11500
30	19550	13800	20700	11500
35	20700	13800	25300	13800
35*	19550	13800	20700	11500
40	20700	14375	25300	13800
40*	19550	13800	20700	11500
45*	32000	24000	35000	26000
50*	32000	24000	35000	26000

* = Version with special fixing holes

UCFS/C - SUCFS/C - HCFS/C - SHCFS/C





Shaft dia. d mm				
	PA FV N	PP FV N	PA FV N	PP FV N
30	20700	25300		
35*	20700	25300		
40*	20700	25300		

* = Version with special fixing holes

F - SF



Shaft dia. d mm						
	PA FV N	PP FV N	PA FV N	PP FV N	PA FV N	PP FV N
30	21850	16100	17250	13800	8050	5750
35	21850	16100	17250	13800	18400	10350
40	21850	17250	17250	13800	19550	13800
40*	21850	16100	17250	13800	18400	10350
45	23000	17250	18400	14350	19550	13800
45*	21850	16100	17250	13800	18400	10350

* = Version with special fixing holes

Bearing unit max. static load

UCFLN/C - SUCFLN/C - HCFLN/C - SHCFLN/C UCFLN/CL - SUCFLN/CL - HCFLN/CL - SHCFLN/CL



Shaft dia. d mm				
	PA FV N	PP FV N	PA FV N	PP FV N
17	9775	6325	9775	6900
20*	9775	6325	9775	6900
25*	10925	7475	11500	7475
30	14950	9200	14375	11500
30*	14950	9200	14375	11500

* = Version with special fixing holes

UCFLN - SUCFLN - HCFLN - SHCFLN



Shaft dia. d mm				
	PA FV N	PP FV N	PA FV N	PP FV N
17	9775	6325	9775	6900
20*	9775	6325	9775	6900
25*	10925	7475	11500	7475
30	14950	9200	14375	11500
30*	14950	9200	14375	11500

* = Version with special fixing holes

UCFL/C - SUCFL/C - HCFL/C - SHCFL/C - UCFL/CL - SUCFL/CL HCFL/CL - SHCFL/CL - UCFL - SUCFL - HCFL - SHCFL



Shaft dia. d mm				
	PA FV N	PP FV N	PA FV N	PP FV N
17	9775	6325	9775	6900
20	9775	6325	9775	6900
25	10925	7475	11500	7475
25*	10925	7475	11500	7475
30	14950	9200	14375	11500
30*	14950	9200	14375	11500
35	14950	9200	13225	10925
35*	14950	9200	14375	11500
40	14950	9775	14950	10925
40*	14950	9200	14375	11500

* = Version with special fixing holes

UCFLS/C - SUCFLS/C - HCFLS/C - SHCFLS/C



Shaft dia. d mm				
	PA FV N	PP FV N	PA FV N	PP FV N
30	14950	14375		
35*	14950	13225		
40*	14950	14950		

* = Version with special fixing holes

FL



Shaft dia. d mm						
	PA FV N	PP FV N	PA FV N	PP FV N	PA FV N	PP FV N
25	9200	6900	11500	8625	12650	5750
30	11500	6900	12650	9200	13800	5750
35	11500	9200	12650	9200	9200	4600
40	12650	9200	12650	9200	13800	6900
45	12650	9200	13800	9775	17250	12650

Bearing unit max. static load



UCFX/T - SUCFX/T - HCFX/T- SHCFX/T



Shaft dia. d mm		
	PA FV N	PA FV N
30	45000	45000
35	45000	45000
40	45000	45000





UCP/C - HCP/C - UCP - HCP



Shaft dia. d mm						
	PA FV N	PP FV N	PA FV N	PP FV N	PA FV N	PP FV N
20	4600	2070	20700	5750	5750	3450
25	6900	2070	20700	5750	6900	3450
30	8050	2300	28750	8050	9200	4600
35	9200	2530	31050	8625	11500	4830
40	9200	2530	31050	8625	11500	4830



UCPA/C - HCPA/C - UCPA - HCPA



Shaft dia. d mm								
	PA FV N	PP FV N	PA FV N	PP FV N	PA FV N	PP FV N	PA FV N	PP FV N
17	2500	1500	8000	3750	1500	1100	1250	1000
20	2500	1700	6750	4300	2300	1200	1100	750
25	3000	1700	10500	5200	2600	1750	1100	900

UCFB/C - HCFB/C - UCFB - HCFB



Shaft dia. d mm				
	PA FV N	PP FV N	PA FV N	PP FV N
20	3000	1700	1000	650
25	3500	2000	1000	650
30	3500	2000	1000	650
35	4000	2500	1000	650
40	5200	3000	1000	650

UCT/C - HCT/C - UCT - HCT





Shaft dia. d mm	
	PA FV N
20	16000
25	24000
30	27000

Bearing unit max. static load



UCFC/C - UCFC



Shaft dia. d mm				
	PA N	FV N	PA N	FV N
35	19550	12650	23000	11500

FC



Shaft dia. d mm						
	PA N	FV N	PA N	FV N	PA N	FV N
35	17250	11500	17250	11500	23000	12650

Bearings

■ Bearings with grub screw locking system

Prelubricated with long lasting lithium/calcium grease • Can be rilubricated

Type A

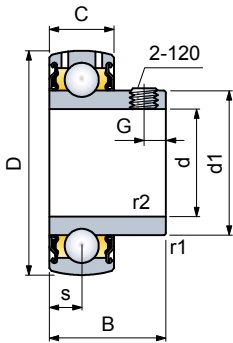

d mm	Dimensions in mm							Load coefficient			Weight Kg
	d1	D	B	C	s	G	r1, r2 min.	Grub screws	dyn. ¹⁾ C N	stat. Co N	
17	24,6	40	22	12	6	4	0,3	M5x0,8	9500	4750	0,07
20	29	47	25	14	7	5	0,6	M6x1	12700	6550	0,11
25	34	52	27	15	7,5	5,5	0,6	M6x1	14000	7800	0,14
30	40,3	62	30	16	8	6	0,6	M6x1	19500	11200	0,23
35	48	72	32	17	8,5	6,5	1	M6x1	25500	15300	0,31
40	53	80	34	18	9	7	1	M8x1	30700	19000	0,43
45	57,2	85	41,2	19	10,2	8,2	1	M8x1	33200	21600	0,48
50	61,8	90	43,5	20	10,9	9,2	1	M8x1	35100	23200	0,54

Chrome alloy steel.

¹⁾ = Values are valid for applications with ≤ h 6 shaft tolerance.

Time 0.77 values must be considered in all other cases.

Type B

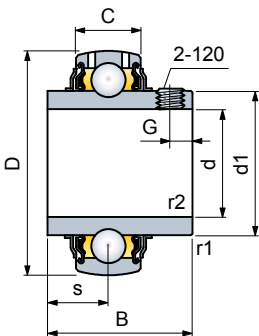

d mm	Dimensions in mm							Load coefficient			Weight Kg
	d1	D	B	C	s	G	r1, r2 min.	Grub screws	dyn. ¹⁾ C N	stat. Co N	
17	24,2	40	27,4	12	11,5	3,5	0,3	M6x0,75	9500	4750	0,09
20	29	47	31	16	12,7	4,7	0,6	M6x1	12700	6550	0,14
25	34	52	34,1	17	14,3	5,5	0,6	M6x1	14000	7800	0,17
30	40,3	62	38,1	19	15,9	5,5	0,6	M6x1	19500	11200	0,28
35	48	72	42,9	20	17,5	6,5	1	M8x1	25500	15300	0,41
40	53	80	49,2	21	19	8	1	M8x1	30700	19000	0,55
45	57,2	85	49,2	22	19	8	1	M8x1	33200	21600	0,60
50	61,8	90	51,6	23	19	9	1	M10x1	35100	23200	0,69

Chrome alloy steel.

¹⁾ = Values are valid for applications with ≤ h 6 shaft tolerance.

Time 0.77 values must be considered in all other cases.

Type C stainless steel

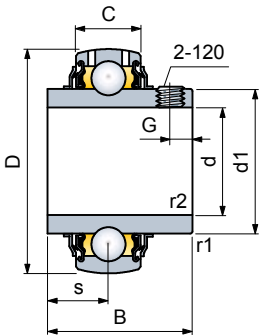

d mm	Dimensions in mm							Load coefficient			Weight Kg
	d1	D	B	C	s	G	r1, r2 min.	Grub screws	dyn. ¹⁾ C N	stat. Co N	
20	29	47	31	17	12,7	5	0,6	M6x1	10800	6550	0,14
25	34	52	34,1	17	14,3	5	0,6	M6x1	11900	7800	0,18
30	40,3	62	38,1	19	15,9	6	0,6	M6x1	16250	11200	0,29
35	48	72	42,9	20	17,5	6	1	M6x1	21600	15300	0,42
40	53	80	49,2	21	19	8	1	M8x1	26000	19000	0,56

Stainless steel AISI 420.

¹⁾ = Values are valid for applications with ≤ h 6 shaft tolerance.

Time 0.77 values must be considered in all other cases.

■ Bearings with self locking eccentric collar

Prelubricated with long lasting lithium/calcium grease • Can be rilubricated • Higher resistance to vibrations • Suitable for single directional travel (cannot reverse the sense of rotation) • Locking of the bearing is achieved by rotating the eccentric collar. The grub screw holds the collar and avoids rotation.

Type D

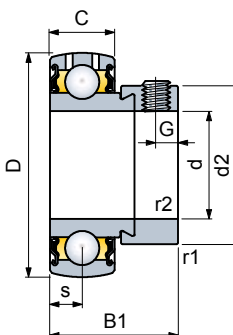

d mm	Dimensions in mm							Load coefficient			Weight Kg
	d2	D	B1	C	s	G	r1, r2 min.	Grub screws	dyn. ¹⁾ C N	stat. Co N	
17	28,6	40	28,6	12	6,5	4,75	0,3	M6x0,75	9500	4750	0,10
20	33,3	47	30,9	14	7,5	5	0,6	M6x1	12700	6550	0,16
25	38,1	52	30,9	15	7,5	5	0,6	M6x1	14000	7800	0,18
30	44,5	62	35,7	16	9	6	0,6	M6x1	19500	11200	0,30
35	51,9	72	38,9	17	9,5	6,5	1	M8x1	25500	15300	0,49
40	60,3	80	43,7	18	11	6,5	1	M8x1	30700	19000	0,62
45	63,5	85	43,7	19	11	6,5	1	M8x1	33200	21600	0,65
50	69,9	90	43,7	20	11	6,5	1	M8x1	35100	23200	0,70

Chrome alloy steel.

¹⁾ = Values are valid for applications with ≤ h 6 shaft tolerance.

Time 0.77 values must be considered in all other cases.

Bearings

Seals

Type A - D. The system consists of a metallic ring fitted with a low friction rubber sealing lip.

Type B. The system is further equipped with a metallic protection ring providing a centrifugal sealing action.

Type C inox. The upper lip of the centrifuging ring together with the grease trapped between the base seal and the ring it self guarantees maximum sealing capacity.

Type A - D

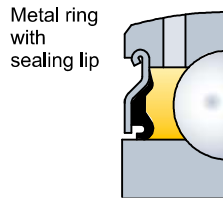

Type B

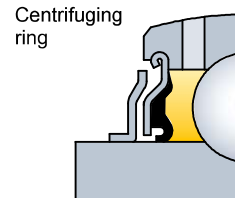

Type C Inox

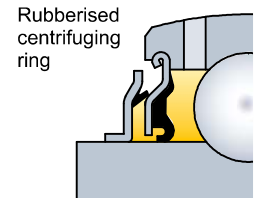

Maximum velocities

The table indicates the values for **A, D, B** series bearings • Stainless steel bearings of the **C** Type (rubberised centrifuging ring) must not be operated at velocities in excess of 60% of the values indicated • The maximum velocity is dependant of the shaft tolerances. Higher tolerances require lower speed

Int. dia. bearing d mm	Shaft tolerance				
	h6	h7	h8	h9	h11
	Speed (RPM)				
17	9500	6000	4300	1500	950
20	8500	5300	3800	1300	850
25	7000	4500	3200	1000	700
30	6300	4000	2800	900	630
35	5300	3400	2200	750	530
40	4800	3000	1900	670	480
45	4300	2600	1700	600	430
50	4000	2400	1600	560	400

Axial load capacities

The bearing locking systems by grub screws/eccentric collars, allow axial loads up to 20% of the dynamic load coefficient (only with non hardened shafts and grub screws tightened as recommended) • For bearings of the **A, D, B, C**, series it is not recommended to exceed the value of: $0,25 \cdot C$

Self aligning ball bearing holding by shoulders on shaft

The bearings have double row of balls running on a spherical outer race This configuration renders the bearing self aligning • The bearings are supplied without sealing units • They are held into position by shoulders on the shaft.

Type 1200

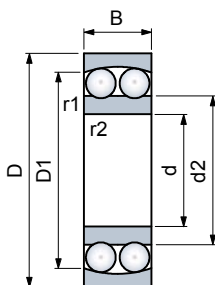

d mm	Bearing type	Dimensions in mm					Load coefficient		Revolutions RPM	Weight Kg
		D	B	d2	D1	r1, r2 min.	dyn. C N	stat. Co N		
20	1204	47	14	28,9	41	1	12700	3400	15000	0,12
25	1205	52	15	33,3	45,6	1	14300	4000	13000	0,14
30	1206	62	16	40,1	53	1	15600	4650	10000	0,22
35	1207	72	17	47	62,3	1,1	19000	6000	9000	0,32
40	1208	80	18	53,6	68,8	1,1	19900	6950	8500	0,42

Calculation data

■ Bearing dimensioning

The bearing dimensions, for a given application, should be chosen on the basis of the loads to be supported, expected service life and reliability. In most cases the reason for choosing a bearing is the fact that the shaft has already been sized during the design of the plant.

■ Calculation procedures for self-aligning bearings

The calculation procedure for self-aligning bearings consists in ensuring a satisfactory operating life of the unit:

- 1) The nominal service life is calculated using the formulas indicated below, keeping in mind the type of stress on the bearing (dynamic or static).
- 2) The nominal life of the bearing should reflect the expected service life of the plant as indicated in Table 1 hereunder.

■ Service life

The dimensioning of the bearing requires the knowledge of the appropriate life expectancy of the project in relation to the specific application. This depends on the type of plant, daily/yearly working hours and on the required reliability. In the absence of practical experience Table 1 gives our recommendations of the average expected plant life under various conditions.

Table 1 - Recommended plant expected life L_{10h} for MB support bearings

Plant type	Plant expected life L_{10h} hours
Seasonal Operation plants	4000 ÷ 8000
Daily operated plant, 8 hours/day, not completely utilised	10000 ÷ 20000
Daily operated plant, 8 hours/day, completely utilised	20000 ÷ 30000
Daily operated plant, 24 hours/day	40000 ÷ 80000

Dynamically stressed bearings

Bearings which rotate under load are considered dynamically stressed (one ring of the bearing makes one full rotation against the other). In most cases, self-aligning supports are dynamically stressed.

■ Expected life calculation formula

The service life of a bearing is expressed in the number of revolutions or hours of operations which can be expected without breakdown (erosion or laminations of the bearing revolving parts).

The calculating procedure for nominal duration is valid whatever the type of bearing:

$$L_{10} = \left(\frac{C}{P}\right)^3 \text{ Life in Millions revolutions.}$$

When bearings rotate at constant speed it is more practical to calculate the life in number of hours:

$$L_{10h} = \frac{16666}{n} \cdot \left(\frac{C}{P}\right)^3 \text{ Life in hours.}$$

L_{10} = life in millions of revolutions.

L_{10h} = life in hours.

C = dynamic load coefficient (N). Values are indicated in the support dimensional tables.

P = equivalent dynamic load (N). See calculation formula on Table 2.

n = revolutions (RPM).

■ Correct expected life

In the majority of cases, for self aligning MB bearings, it is sufficient to calculate L_{10} , L_{10h} using the formula indicated above. The new theory of life calculation permits to establish the correct life expectancy keeping into consideration the effects of lubrication, pollution of solid particles and of the fatigue limit load P_u (values are reported in the bearing tables). The calculation of the correct expected life requires therefore the assistance of the technical commercial staff.

Calculation data

■ **Equivalent dynamic load P calculation**

Table 2 - Equivalent dynamic load P calculation

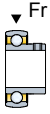
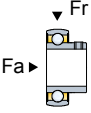
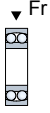
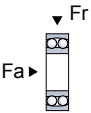
Bearing Type	Load direction on the bearing	Equivalent dynamic load P (N) calculation formula
A B C D		$P = Fr$
		$P = X \cdot Fr + Y \cdot Fa$
1200		$P = Fr$
		$P = Fr + Y1 \cdot Fa$ with $\frac{Fa}{Fr} \leq e1$ $P = 0,65 \cdot Fr + Y2 \cdot Fa$ with $\frac{Fa}{Fr} > e1$

P = equivalent dynamic load (N).
Fr = radial load acting on the bearing (N).
Fa = axial load acting on the bearing (N).
x, Y = load factors. See Table 3.
e1, Y1, Y2 = factors. See Table 4.

Table 3 - Load factors x, y

Ratio $\frac{Fa}{Co}$	e	With: $\frac{Fa}{Fr} \leq e$		With: $\frac{Fa}{Fr} > e$	
		x	y	x	y
0,025	0,22	1	0	0,56	2
0,04	0,24	1	0	0,56	1,8
0,07	0,27	1	0	0,56	1,6
0,13	0,31	1	0	0,56	1,4
0,25	0,37	1	0	0,56	1,2
0,5	0,44	1	0	0,56	1

Table 4 - Factors e1, Y1, Y2, Yo

Int. dia. bearing mm	e1	Y1	Y2	Yo
20	0,30	2,1	3,3	2,2
25	0,28	2,2	3,5	2,5
30	0,25	2,5	3,9	2,5
35	0,23	2,7	4,2	2,8
40	0,22	2,9	4,5	2,8

Co = Static load coefficient (N).
 The values are indicated in the support dimensional tables.

■ **Operating conditions coefficients**

It should be common practice to include operational factors when calculating bearing dimensions to allow for load variations which may happen during running of the plant. The coefficients given here under are indicative only and are based on actual operational experience.

With steady loads/light impacts: multiply the equivalent dynamic load P by: 1,2 ÷ 1,5
 With loads and medium impacts: multiply the equivalent dynamic load P by: 1,7 ÷ 2,0

Calculation data

■ Static load capacity control

Statically stressed bearings

In rolling-contact bearing technology the condition of static load is considered to exist when:

- The bearing does not rotate and is subjected to permanent loads or intermittent ones (impacts).
- The bearing is subjected to loads and slow oscillating movements.
- The bearing rotates under load at a very low speed and for short periods.
- The bearing rotates under load and must withstand strong impacts acting in the course of one revolution.

The static safety coefficient f_s must not exceed the recommended values given in Table 5 in order to obtain a satisfactory performance of the bearings. Coefficient f_s gives the safety margin against excessive permanent deformation of the revolving parts of the bearing.

$$f_s = \frac{C_o}{P_o}$$

f_s = static safety coefficient.
 C_o = static load coefficient (N). The values are given in the support dimensional tables.
 P_o = equivalent static load (N). See calculation formula given below.

Table 5 - Static safety coefficient f_s for MB bearings

Type of operation	Revolving bearings			Non revolving bearings
	Noise level not important	Normal noise level operation	Low noise level operation	
Smooth operation without vibration	5	1	2	0,4
Normal operation	0,5	1	2	0,5
Impact loads operation	$\geq 1,5$	$\geq 1,5$	≥ 2	≥ 1

■ Equivalent static load P_o calculation

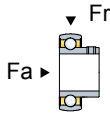
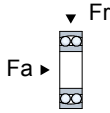
Bearing type	Load direction on the bearing	Equivalent dynamic load P (N) calculation formula
A B C D		$P_o = 0,6 \cdot Fr + 0,5 \cdot Fa$ If $P_o < Fr$, then assume $P_o = Fr$.
1200		$P_o = Fr + Y_o \cdot Fa$

P_o = equivalent static load (N).
 Fr = radial load on the bearing (N).
 Fa = axial load on the bearing (N).
 Y_o = see table 4.

Lubrication

■ Prelubrication

All self-aligning bearings are supplied factory lubricated.

Warning

The first lubrication must be carried out only for bearings of the series FL - F - FC held by the shaft shoulders.

■ Lubricating grease

Bearings are prelubricated with long lasting lithium/calcium grease.

Technical data	NLGI consistency:	2
	Emulsifier:	lithium/calcium
	Base oil:	mineral
	Base oil viscosity:	165 mm ² /s at 40°C
	Operating temperature:	- 20°C to +120°C
	Water resistance:	Recommended
	Antioxidant properties:	Recommended

■ Relubrication

All self-aligning bearing units are equipped with a grease nipple of the ball type to allow periodical relubrication of the bearing.

Warning

- Do not grease at first assembly.
- The first lubrication must be carried out only for bearings of the series FL - F - FC held by the shaft shoulders.
- Stainless steel pressed metal supports of the series SBF are not relubricatable.
- Use only grease of same characteristics as indicated.
- Clean greasing nipple before each greasing operation.
- Inject grease slowly until it comes out from the bearing.
Keep the bearing rotating and do not apply excessive pressure which could damage the sealing units.
- More frequent greasing operations with smaller quantities of grease are to be preferred.

■ Relubrication intervals

Relubrication intervals vary according to actual operating conditions. Very often during operation, load, speed, temperature and ambient conditions (humidity, dust) may vary making it difficult to establish exact rules. Experience once again gives the best answer:

- Light operating conditions: relubricate every 6 months.
- Normal operating conditions: relubricate every 1+3 months.
- Heavy operating conditions: relubricate every 2 weeks.

Grease life in bearings lubricated for life

(dry use recommended)

Formula to calculate grease life in bearings lubricated for life

This procedure allows to calculate the grease life as a function of its quality and bearing type, dimension, rotating speed, applied loads and working temperature.

$$L_h = L_{10} \times F_c \text{ Grease life (hours)}$$

- L_h = Grease life (hours).
- L_{10h} = Grease nominal life (hours). See Diagram 1.
- F_c = Correction factor. See Diagram 2.

Diagram 1
- Grease nominal life L_{10h}

This diagram allows to determine the nominal grease life L_{10h} (hours), as a function of rotating speed n (rpm), mean diameter dm (mm), bearing working temperature ($^{\circ}C$). Greases are classified by a factor GPF (Grease Performance Factor), related to their temperature performance. In this table we consider a grease with GPF = 1, which is the grease used in all Marbett LifeLube bearings.

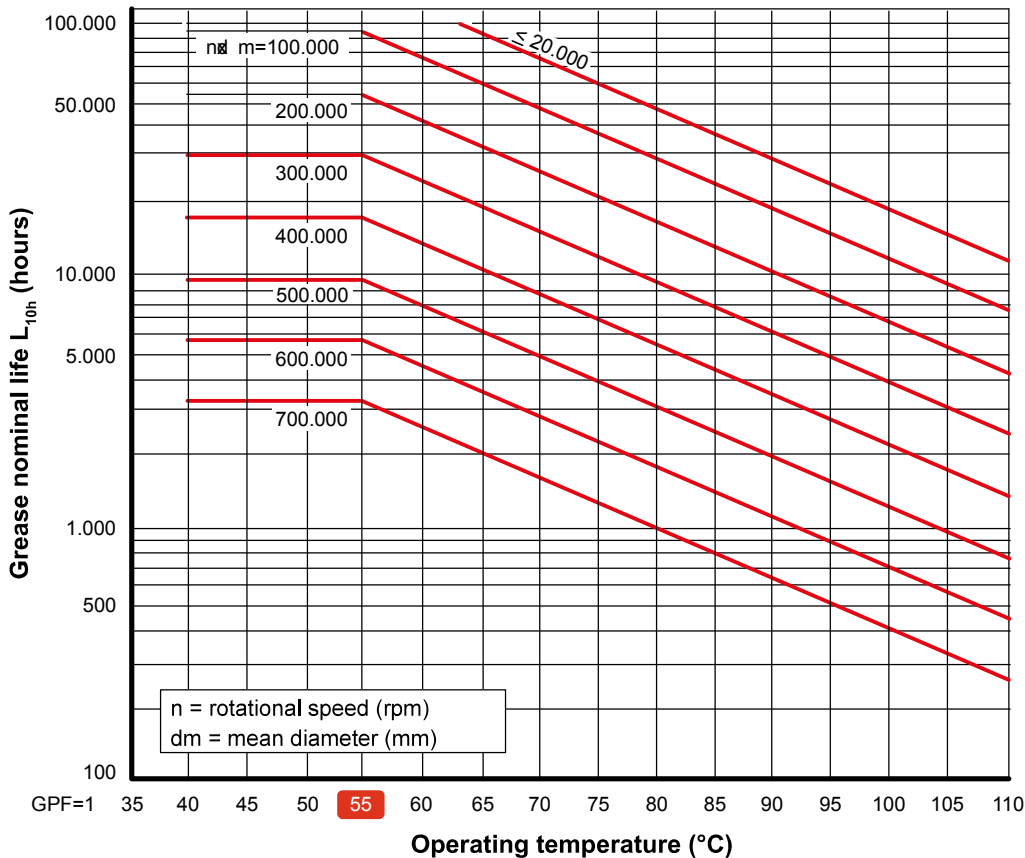

dm (mm) = mean diameter.

Type A

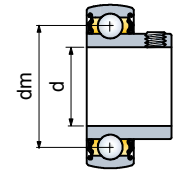

Type D

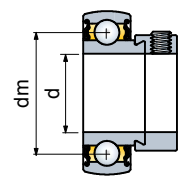

dia. d mm	dia. dm mm
17	28,5
20	33,5
25	38,5
30	46
35	53,5
40	60
45	65
50	70

55 = At room temperature, with normal working conditions, the grease works at a temperature lower than 55 $^{\circ}C$.

Grease life in bearings lubricated for life

(dry use recommended)

■ **Diagram 2 - Correction factor Fc**

The corrective factor Fc, keeps into consideration the influence of load applied on bearings as a function of load ratio C/P. With low loads ($C/P \geq 15$) the duration of the grease is not influenced by load values.

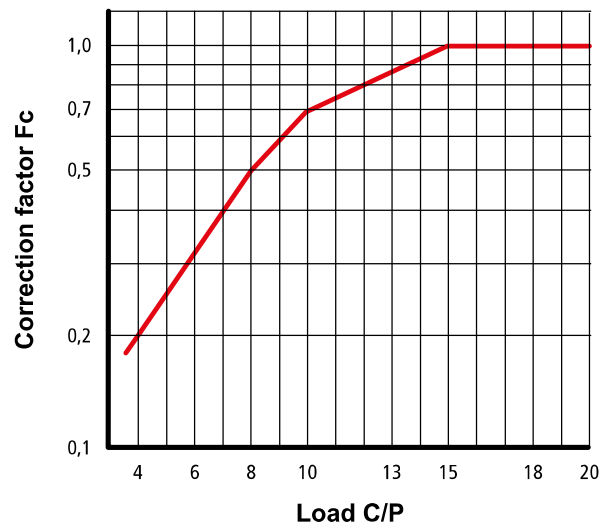

C = Dynamic load coefficient (N).
 Values are indicated in the bearings dimensional tables.
 P = Equivalent dynamic load (N).
 See Table 2.

■ **Example of calculation**

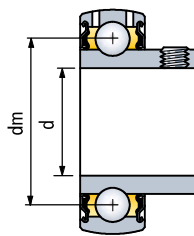

Data:

- Bearing Type A.
- d = 40 mm (shaft dia.).
- dm = 60 mm. (bearing mean dia.).
- n = 300 rpm. (rotational speed).
- 55 °C (grease operating temperature).
- C = 23600 N (Dynamic load coefficient).
- P = 3000 N (equivalent dynamic load).

- From Diagram 1, as a function of:
 $n \times dm = 300 \text{ rpm} \times 60 \text{ mm} = 18000$
 we read a nominal grease life of:
 $L_{10h} = 100000 \text{ hours.}$

- From Diagram 2, as a function of:
 $C/P = 23600 \text{ N} : 3000 \text{ N} = 7,8$
 we read a corrective factor of:
 $Fc = 0,5.$

- Calculation of estimated grease life:
 $L_n = L_{10h} \times Fc = 100000 \text{ hours} \times 0,5 = 50000 \text{ hours.}$

Shaft tolerances

**Tolerances for grub screws/
eccentric collar locked bearings**

- The tables indicate shaft diameter tolerances.
- Shaft ends must be rounded off in order to:
 - ease assembly and avoid bearing jamming.
 - avoid damages to the rubber parts of the sealing units.
- The shaft surface for the portion in contact with the sealing gaskets must be smooth and free of defects (scratches etc.).

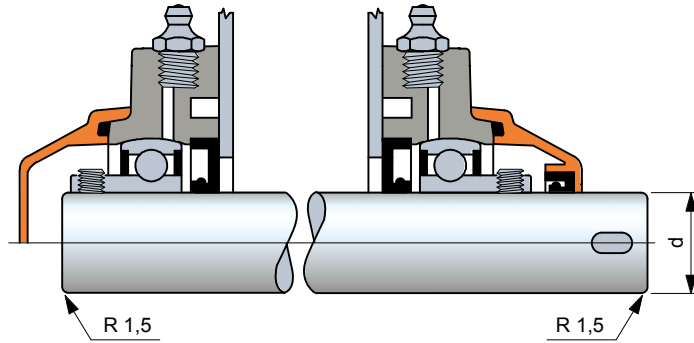

ISO shaft tolerance

Shaft dia. d mm	Heavy loads High speed		Normal operation		Light loads Low speed		Simple applications					
	h 6		h 7		h 8		h 9		h 10		h 11	
	plus	min.	plus	min.	plus	min.	plus	min.	plus	min.	plus	min.
17	0	-11	0	-18	0	-27	0	-43	0	-70	0	-110
20 ÷ 30	0	-13	0	-21	0	-33	0	-52	0	-84	0	-130
35 ÷ 50	0	-16	0	-25	0	-39	0	-62	0	-100	0	-160

Tolerances in μm

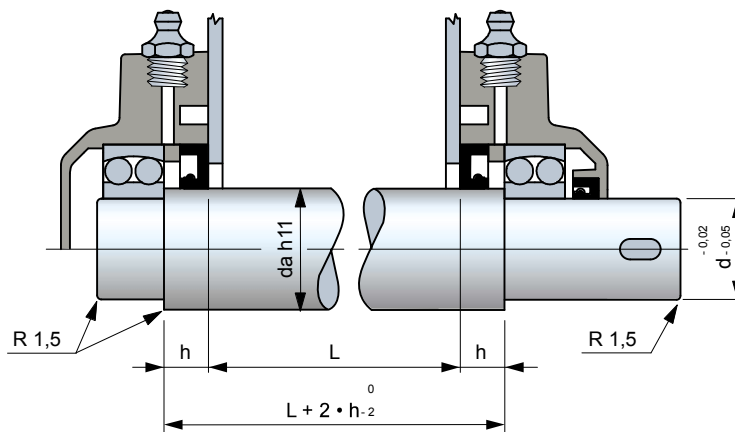

h values are given in the support dimensional tables

**Tolerances for shaft shoulders
locked bearings**

- Shaft ends must be rounded off in order to:
 - ease assembly and avoid bearing jamming.
 - avoid damages to the rubber parts of the sealing units.
- The shaft surface for the portion in contact with the sealing gaskets must be smooth and free of defects (scratches etc.).
- The mounting shaft/bearing is free to facilitate assembly.
For heavy radial loads conditions it is recommended a slightly tight mounting.

Mounting

■ Assembly instructions

1 - With waterproof bearings the rubber sealing units must be greased before mounting to avoid initial dry running on the shaft. The grease must fill only the space in between the two sealing lips.

2 - The bearing must be locked onto the shaft after the support mounting flange has been fully tightened. This is necessary to allow the bearing to assume its correct alignment on the shaft without undue axial stresses. Always tighten the screws diagonally.



■ Locking of the bearing by grub screws

3 - The table gives the recommended maximum tightening couples for the grub screws and the size of the hexagonal to use.



Int. dia. bearing mm	Sc. driver size mm			Max. tightening couple Nm		
	Bearings A AC		Bearings D	Bearings A AC		Bearings D
	A	AC	D	A	AC	D
17	2,5	3	3	3,5	4	4
20	3	3	3	4	4	4
25	3	3	3	4	4	4
30	3	3	3	4	4	4
35	3	4	4	4	6,5	6,5
40	4	4	4	6,5	6,5	6,5
45	4	4	4	6,5	6,5	6,5
50	4	5	4	6,5	16,5	6,5

■ Locking of the bearings by eccentric collar

4 - Tighten the collar by turning it with a punch in the same direction as the rotation of the shaft.

5 - Hand tighten the grub screw. The screw driver dimension and the tightening couple are given in the table above (Ref. D series bearings).



■ Assembly / removal of the protection cover

6 - Assembly. The sealing unit of open end covers must be greased to avoid initial dry running on the shaft. The grease must fill only the space in between the two sealing lips.

7 - Removal. Insert a screw driver into the groove provided for and force the cover out.



Resistance against chemical agents	POLYAMIDE	POLYPROPYLENE	POLYETHYLENE	ACETAL	AISI 303	AISI 316	NICKEL PLATED	NBR	VITON
	PA	PP	PE	POM	AISI 304		BRASS	RUBBER	RUBBER
CHEMICAL AGENT	Conc.% 23°C	Conc.% 23°C	Conc.% 23°C	Conc.% 23°C	Conc.% 23°C	Conc.% 23°C	Conc.% 23°C	Conc.% 23°C	Conc.% 23°C
PHENOL	-	+			10 +	+		-	+
PHOSFORIC ACID	10 -	85 +	95 +	10 -	10 -	50 /	-	20 /	85 +
POTASSIUM HYDROXIDE	10 +				50 +	50 +		/	+
SEA WATER	+	+	+	/	+	+	+	+	+
SILICONE OIL	+	+						+	+
SILVER NITRATE	+	20 +			60 /			/	+
SOAP AND WATER	+	+	+	+	+			+	
SODIUM CARBONATE	10 +	Sat. +	+	+	5 +	100 +		+	+
SODIUM CHLORIDE	10 +	Sat. +	+	+	5 +	/	+	+	Sat. +
SODIUM HYDROXIDE	10 +	30 +	+	10 +	-		+	/	
SODIUM HYPOCHLORITE	+	20 +	+	-	-			-	5 +
SODIUM SILICATE	+				100 +	100 +		+	
SODIUM SULPHATE	10 +	Sat. +	+	+	5 +	100 +		+	+
SOFT DRINKS	+	+	+	+	+		+	+	
SUDS	+	+						+	+
SULPHURIC ACID	10 -	98 +	40 /	40 -	10 -	100 +	+	-	95 +
TARTARIC ACID	+	10 +	+	30 /	10 +	50 +	-	+	+
TETRALINE	+	-						-	+
TINCTURE OF IODINE	-	+	+	+			-	/	
TRANSFORMER OIL	+	/						+	+
TRICHLOROETHYLENE	/	/	+	-	+		+	-	+
TURPENTINE	/	-	-	-	+			-	
VASELINE	+	+	/	+				+	+
VEGETABLE JUICES	+	+	+	+	+			+	
VEGETABLE OILS	+	+	+	+	+			+	
VINEGAR	+	+	+	+	+		+	/	-
WHISKY	+	+	+	+	+		+	+	+
WINE	+	+	+	+	+		+	+	+
XILOL	+	-	/	+	+		/	-	+
ZINC CHLORIDE	10 /	20 +			10 -	/		+	Sat. +

Abbreviations: Sat. = saturated.

Legend..

- + = Good resistance.
- / = Fairly good resistance (limited use depending on working conditions).
- = Poor resistance (not recommended).
- N.B. Where tests have not been carried out the spaces are left blank.

The data shown in this table..

are taken from laboratory tests, performed on unstrained test samples. It should be considered as purely indicative since material behaviour under real working conditions depends on different factors: temperature, concentration of the chemical agent, quick or long-lasting effect of the chemical agent.

Operating temperatures

Material	Description	Operating temperatures (°C)		
		Min	Max	Max
PA	Polyamid	0	+ 80	+ 65
PA FV	Reinforced polyamid	- 5	+ 120	+ 100
PP	Polypropylene	+ 5	+ 105	+ 105
PP FV	Reinforced polypropylene	+ 5	+ 115	+ 115
PE (UHMWPE)	Polyethylene	- 40	+ 80	+ 70
POM	Acetal	- 40	+ 80	+ 65
Rex-LF®	Acetal	- 40	+ 80	+ 65
AISI 303 - AISI 304	Austenitic stainless steel (18/8)	- 70	+ 430	+ 120
Fe Zn	Zinc plated steel	- 40	+ 180	-
OT	Nickel plated brass	- 40	+ 180	+ 120

	Page.		Page.		Page.		Page.
Part. S0000	S109	Part. S0275	S025	Part. S0580	S064	Part. S0766	S022
Part. S0050	S098	Part. S0275	S087	Part. S0581	S060	Part. S0767	S020
Part. S0061	S110	Part. S0280	S125	Part. S0581	S061	Part. S0767	S052
Part. S0063	S083	Part. S0296	S058	Part. S0594	S045	Part. S0768	S020
Part. S0070	S096	Part. S0298	S101	Part. S0599	S103	Part. S0768	S052
Part. S0071	S096	Part. S0303	S143	Part. S0611	S127	Part. S0770	S051
Part. S0073	S028	Part. S0308	S046	Part. S0612	S152-S153	Part. S0771	S043
Part. S0075	S154	Part. S0317	S048	Part. S0613	S033	Part. S0782	S030
Part. S0082P	S094	Part. S0337	S140	Part. S0614	S033	Part. S0784	S007
Part. S0107	S103	Part. S0338	S113	Part. S0615	S126	Part. S0786	S121
Part. S0126	S028	Part. S0339	S120	Part. S0616	S129	Part. S0787	S030
Part. S0128	S082-S083	Part. S0340	S118	Part. S0617	S104	Part. S0814	S010
Part. S0137	S132	Part. S0341	S136	Part. S0618	S127	Part. S0822	S004
Part. S0140	S104	Part. S0342	S136	Part. S0619	S128	Part. S0825	S004
Part. S0153	S027	Part. S0346	S050	Part. S0632	S105	Part. S0826	S031
Part. S0159	S095	Part. S0356	S021	Part. S0634	S010	Part. S0827	S031
Part. S0174	S118	Part. S0362	S007	Part. S0637	S106	Part. S0837	S156
Part. S0182	S144	Part. S0366	S014	Part. S0642	S056	Part. S0840	S006
Part. S0183	S144	Part. S0367	S014	Part. S0643	S056	Part. S0846	S148
Part. S0184	S100	Part. S0368	S015	Part. S0645	S057	Part. S0847	S148
Part. S0185	S145	Part. S0369	S012	Part. S0654	S045	Part. S0848	S148
Part. S0190	S100	Part. S0369	S054	Part. S0657	S035	Part. S0849	S148
Part. S0191	S058	Part. S0371	S017	Part. S0661	S116	Part. S0850-S0865	S148
Part. S0192	S108	Part. S0372	S138	Part. S0662	S097	Part. S0852	S081
Part. S0198	S124	Part. S0378	S059	Part. S0672	S146	Part. S0854	S081
Part. S0199	S122	Part. S0387	S008	Part. S0674	S011	Part. S0856	S078
Part. S0210P	S086	Part. S0393	S047	Part. S0685	S135	Part. S0857	S079
Part. S0211	S087	Part. S0421	S029	Part. S0686	S134	Part. S0858	S016
Part. S0213	S088	Part. S0422	S054	Part. S0692	S114	Part. S0862	S107
Part. S0213	S088	Part. S0518	S139	Part. S0694	S090	Part. S0864	S148
Part. S0215	S025	Part. S0523	S037	Part. S0698	S097	Part. S0868	S070
Part. S0215	S091	Part. S0523	S037	Part. S0699	S115	Part. S0868	S072
Part. S0217	S090	Part. S0524	S036	Part. S0708	S102	Part. S0869	S071
Part. S0218	S085	Part. S0533	S039	Part. S0715	S043	Part. S0869	S073
Part. S0219	S049	Part. S0535	S065	Part. S0725	S111	Part. S0885	S013
Part. S0223	S023	Part. S0537	S065	Part. S0729	S036	Part. S0885	S015
Part. S0223	S048	Part. S0539	S057	Part. S0732	S116	Part. S0902	S024
Part. S0226	S112	Part. S0550	S018	Part. S0736	S089	Part. S0903	S024
Part. S0237	S092	Part. S0554	S032	Part. S0737	S089	Part. S0903	S091
Part. S0241	S003	Part. S0555	S034	Part. S0754	S075	Part. S0905	S150-S151
Part. S0243	S003	Part. S0556	S032	Part. S0755	S067	Part. R0098	R10-R11
Part. S0244	S006	Part. S0557	S062	Part. S0755	S069	Part. R0133	R14-R15
Part. S0247	S049	Part. S0562	S130	Part. S0756	S074	Part. R0134	R20
Part. S0247	S092	Part. S0563	S130	Part. S0756	S076	Part. R0173	R08-R09
Part. S0251	S005	Part. S0564	S131	Part. S0757	S066	Part. R0180	R40
Part. S0256	S107	Part. S0565	S042	Part. S0757	S068	Part. R0224	R41
Part. S0260	S140	Part. S0567	S146	Part. S0758	S034	Part. R0297	R21
Part. S0261	S005	Part. S0568	S147	Part. S0760	S080	Part. R0323	R12-R13
Part. S0262	S002	Part. S0569	S147	Part. S0763	S117	Part. R0349	R34
Part. S0272	S142	Part. S0570	S063	Part. S0765	S021	Part. R0406	R39
Part. S0273	S053	Part. S0580	S062	Part. S0765	S053	Part. R0408	R35

Numerical Index

	Page.		Page.
Part. R0479	R16-R17	Part. UCF/C	B04
Part. R0622	R26-R27	Part. UCF/CL	B06
Part. R0623	R28-R29	Part. UCFB	B30
Part. R0626	R22-R23	Part. UCFB/C	B28
Part. R0627	R23-R25	Part. UCFC	B40
Part. R0628	R30-R31	Part. UCFC/C	B38
Part. R0629	R32-R33	Part. UCFL	B20
Part. R0747	R36	Part. UCFL/C	B18
Part. R0747F	R37	Part. UCFLN	B16
Part. R0748	R36	Part. UCFLN/C	B14
Part. R0748F	R37	Part. UCFS/C	B10
Part. R0749	R36	Part. UCP	B24
Part. R0750S	R38	Part. UCP/C	B22
Part. R0750SF	R38	Part. UCPA/C	B26
Part. R0869	R18-R19	Part. UCT/C	B36
Part. F	B12		
Part. HCF	B08		
Part. HCF/C	B04		
Part. HCF/CL	B06		
Part. HCFB	B30		
Part. HCFB/C	B28		
Part. HCFL	B20		
Part. HCFL/C	B18		
Part. HCFLN	B16		
Part. HCFLN/C	B14		
Part. HCFS/C	B10		
Part. HCP	B24		
Part. HCP/C	B22		
Part. HCPA/C	B26		
Part. HCT/C	B36		
Part. SBF	B42		
Part. SF	B12		
Part. SHCF	B08		
Part. SHCF/C	B04		
Part. SHCF/CL	B06		
Part. SHCFL	B20		
Part. SHCFL/C	B18		
Part. SHCFLN	B16		
Part. SHCFLN/C	B14		
Part. SHCFS/C	B10		
Part. SQL	B34		
Part. SQL/C	B32		
Part. SUCF	B08		
Part. SUCF/C	B04		
Part. SUCF/CL	B06		
Part. SUCFL	B20		
Part. SUCFL/C	B18		
Part. SUCFLN	B16		
Part. SUCFLN/C	B14		
Part. SUCFS/C	B10		
Part. UCF	B08		

Why Choose Rexnord?

When it comes to providing highly engineered products that improve productivity and efficiency for industrial applications worldwide, Rexnord is the most reliable in the industry. Commitment to customer satisfaction and superior value extend across every business function.

Delivering Lowest Total Cost of Ownership

The highest quality products are designed to help prevent equipment downtime and increase productivity and dependable operation.

Valuable Expertise

An extensive product offering is accompanied by global sales specialists, customer service and maintenance support teams, available anytime.

Solutions to Enhance Ease of Doing Business

Commitment to operational excellence ensures the right products at the right place at the right time.



REXNORD

Rexnord Company Overview

Rexnord is a growth-oriented, multi-platform industrial company with leading market shares and highly trusted brands that serve a diverse array of global end markets.

Process & Motion Control

The Rexnord Process & Motion Control platform designs, manufactures, markets and services specified, highly engineered mechanical components used within complex systems where our customers' reliability requirements and the cost of failure or downtime are extremely high.

Water Management

The Rexnord Water Management platform designs, procures, manufactures and markets products that provide and enhance water quality, safety, flow control and conservation.